STANDARDS GUIDE

ISO/TC 211 GEOGRAPHIC
INFORMATION/GEOMATICS

2009-06-01

TABLE OF CONTENTS

TABLE OF CONTENTS	2
INTRODUCTION	4
INTERNATIONAL STANDARDIZATION AND THE ROLE OF ISO	4
PREFACE	5
ISO/TC 211 ADVISORY GROUP ON OUTREACH	5
SCOPE OF ISO/TC 211	7
BACKGROUND	7
STANDARDIZATION CHALLENGES FOR THE GEOSPATIAL COMMUNITY	9
<i>Location Based Services and Spatial-Enablement</i>	9
<i>Internet, GPS & Mobile Communications Impacts on Geo-Spatial Applications</i>	10
THE ISO/TC 211 USER COMMUNITY	13
<i>ISO/TC 211 Class A Liaisons</i>	13
<i>Global Spatial Data Infrastructure (GSDI)</i>	14
<i>UN Geographic Information Working Group (UNGIWG)</i>	14
<i>Infrastructure for Spatial Information in Europe (INSPIRE)</i>	14
SUMMARIES: PUBLISHED ISO/TC 211 STANDARDS	16
<i>Standards that specify the infrastructure for geospatial standardization</i>	16
<i>Standards that describe data models for geographic information</i>	16
<i>Standards for geographic information management</i>	16
<i>Standards for geographic information services</i>	17
<i>Standards for encoding of geographic information</i>	17
<i>Standards for specific thematic areas</i>	17
INFRASTRUCTURE STANDARDS	18
<i>ISO 19101:2002 Geographic information — Reference Model</i>	19
<i>ISO/TS 19103:2005 Geographic information — Conceptual Schema Language</i>	22
<i>ISO/TS 19104:2008 Geographic information — Terminology</i>	23
<i>ISO 19105:2000 Geographic information — Conformance and testing</i>	24
<i>ISO 19106:2004 Geographic information — Profiles</i>	25
DATA MODEL STANDARDS	26
<i>ISO 19109:2005 Geographic information — Rules for application schema</i>	27
<i>ISO 19107:2003 Geographic information — Spatial schema</i>	30
<i>ISO 19123:2005 – Geographic information — Schema for coverage geometry and functions</i>	33
<i>ISO 19108:2002 Geographic information — Temporal schema</i>	36
<i>ISO 19141:2008 Geographic information — Schema for moving features</i>	39
<i>ISO 19137:2007 Geographic information — Core profile of the spatial schema</i>	42
GEOGRAPHIC INFORMATION MANAGEMENT STANDARDS	43
<i>ISO 19110:2005 Geographic information — Methodology for feature cataloguing</i>	44
<i>ISO 19111:2007 Geographic information — Spatial referencing by coordinates</i>	46
<i>ISO 19112:2003 Geographic information — Spatial referencing by geographic identifiers</i>	48
<i>ISO 19113:2002 Geographic information — Quality principles</i>	50
<i>ISO 19114:2003 Geographic information — Quality evaluation procedures</i>	52
<i>ISO 19115:2003 Geographic information — Metadata</i>	54
<i>ISO 19131:2007 Geographic information — Data product specifications</i>	57
<i>ISO 19135:2005 Geographic information — Procedures for item registration</i>	58
<i>ISO/TS 19127:2005 Geographic information — Geodetic codes and Parameters</i>	60
<i>ISO/ts 19138:2006 Geographic information — Data quality measures</i>	62
GEOGRAPHIC INFORMATION SERVICES STANDARDS	63
<i>ISO 19119:2005 Geographic information — Services</i>	64

<i>ISO 19116:2004 – Geographic information — Positioning services</i>	<i>67</i>
<i>ISO 19117:2005 Geographic information — Portrayal.....</i>	<i>70</i>
<i>ISO 19125-1:2004 Geographic information — Simple feature access — Part 1: Common architecture</i>	<i>72</i>
<i>ISO 19125:2004 Geographic information — Simple feature access — Part 2: SQL option.....</i>	<i>74</i>
<i>ISO 19128:2005 Geographic information — Web map server interface.....</i>	<i>76</i>
<i>ISO 19132:2007 Geographic information — Location based services — Reference model.....</i>	<i>78</i>
<i>ISO 19133:2005 Geographic information — Location based services — Tracking and navigation.....</i>	<i>81</i>
<i>ISO 19134:2007 Geographic information — Location based services — Multimodal routing and navigation</i>	<i>83</i>
GEOGRAPHIC INFORMATION ENCODING STANDARDS	84
<i>ISO 19118:2005 Geographic information — Encoding.....</i>	<i>85</i>
<i>ISO 6709:2008 Standard representation of geographic location by coordinates.....</i>	<i>87</i>
<i>ISO 19136:2007 Geographic information — Geography Markup Language (GML).....</i>	<i>89</i>
<i>ISO/TS 19139:2007 Geographic information — Metadata — XML schema implementation</i>	<i>92</i>
STANDARDS FOR SPECIFIC THEMATIC AREAS	93
<i>ISO/TS 19101-2:2008 Geographic information — Reference model — Part 2: Imagery.....</i>	<i>94</i>
<i>ISO/TS 19115-2:2008 Geographic information — Metadata — Part 2: Extensions for imagery and gridded data.....</i>	<i>96</i>
ISO/TC 211 AND THE OPEN GEOSPATIAL CONSORTIUM.....	98

INTRODUCTION

INTERNATIONAL STANDARDIZATION AND THE ROLE OF ISO

“The foremost aim of international standardization is to facilitate the exchange of goods and services through the elimination of technical barriers to trade.

Three bodies are responsible for the planning, development and adoption of International Standards: ISO (International Organization for Standardization) is responsible for all sectors excluding electrotechnical, which is the responsibility of IEC (International Electrotechnical Committee), and most of the Telecommunications Technologies, which are largely the responsibility of ITU (International Telecommunication Union).

ISO is a legal association, the members of which are the National Standards Bodies (NSBs) of some 130 countries (organizations representing social and economic interests at international level), supported by a Central Secretariat based in Geneva, Switzerland.

The principal deliverable of ISO is the International Standard.

An International Standard embodies the essential principles of global openness and transparency, consensus and technical coherence. These are safeguarded through its development in an ISO Technical Committee (ISO/TC), representative of all interested parties, supported by a public comment phase (the ISO Technical Enquiry). ISO and its Technical Committees are also able to offer the ISO Technical Specification (ISO/TS), the ISO Public Available Specification (ISO/PAS) and the ISO Technical Report (ISO/TR) as solutions to market needs. These ISO products represent lower levels of consensus and have therefore not the same status as an International Standard.

ISO offers also the Industry Technical Agreement (ITA) as a deliverable which aims to bridge the gap between the activities of consortia and the formal process of standardization represented by ISO and its national members. An important distinction is that the ITA is developed by ISO workshops and fora, comprising only participants with direct interest, and so it is not accorded the status of an International Standard.”

PREFACE

ISO/TC 211 ADVISORY GROUP ON OUTREACH

The ISO/TC 211 Advisory Group on Outreach seeks to promote the awareness, adoption, and advocacy of ISO/TC 211 standards.

The ultimate benefits of standardization are based on the use of widely recognized and accepted international voluntary standards developed to the highest technical level by an open consensus process that includes all those affected. Beyond standardization of traditional geographic functionality: innovative, new, and unknown technology and application domains present challenges transcending the established process of geographic standardization. Previously, standardization was a process for recognizing and codifying the status quo of technology. Standardization is now more anticipatory and beginning to carefully define the requirements and implementation of new technology, but not interfere or bias development.

The implied mandate for ISO/TC 211 is to develop an integrated set of standards for geographic information. Equally important, if not more so, is the un-stated strategic direction for the international deployment of such standards. Accordingly, the strategic directions for ISO/TC 211 can be viewed in terms of development, deployment, and the underlying coordination and consensus process that integrates both these phases for successful standardization.

For development, the major issues include: standards technical development, organizations developing geographic or related standards, priorities of standards, standards and interoperability testing, and speed of developing and approving technical specifications. For deployment, the key issues are: implementation of standards, standards education / training, and user communities supporting ISO/TC 211 standards.

Inherent and pervasive through standards development, deployment, and their coordination and consensus process are considerations for the implementers and users of geographic standards. Such as data transfer standards that are implemented by vendors or data cataloguing standards implemented by data producers, or metadata standards implemented by vendors, data producers, and general users of geographic information. Implementers and user requirements need to be considered in conjunction with the standards development, deployment, the process of integrating such requirements.

Traditionally, geographic information is produced and used by the geographic community. Increasingly, geographic information is being created and used by everyone else, and even by the business community. Hence, the once all-important technical issues for experts are now being subordinated to the business issues confronting government and commercial organizations. Previously, the cost of standardization was minimal because of the number of users and requirements. Because geographic information has transitioned, in many countries, from being the essence of national mapping organizations to being the common commodity of consumers in the electronic/Internet/wireless communities – the diverse requirements, costs, and complexity for geographic standardization is increasing dramatically.

The greatest challenges for geographic standardization are internal and external. Internally, the geographic community must overcome the prevailing perception, by both the geographic and non-geographic communities, of the usual applications of geographic information. When in reality, geographic information has outgrown its traditional uses and has assumed an integral part of the latest and forthcoming technological innovations. Externally, modern businesses and companies are recognizing the value of incorporating location-based information as part of their products, services,

and solutions to differentiate themselves within existing and new markets. The location-based market is expected to be a multi-billion dollar industry in just a few years. The strategic directions for geographic standardization need to be responsive to these challenges in a timely manner, else, the geographic community will again be guilty of relinquishing its mandate to outsiders that have only a superficial knowledge of the value and extent of geographic information, but are able to exploit geographic information commercially.

For geographic information standards, its value is in the interoperability of geographic databases and applications and its current work will be to enable access to these databases and applications from a multitude of mobile devices – and to a large extent, independent of much of the impacts from the telecommunications industry. Currently, there is a definite and new direction emerging - towards providing the framework for domain specific standards that unify and integrate information communities. Hence, for the foreseeable future, geographic information is rapidly being recognized as being important beyond the traditional domain of geography and will become pervasive and ubiquitous.

This ISO/TC 211 Standards Guide is compiled from text and diagrams from published ISO/TC 211 standards and intends to provide a concise reference document comprised of general overviews and Unified Modeling Language (UML) diagrams that depict the relationships of the internal components of the standard as well as the relationships of that standard with the other standards within the ISO/TC 211 – ISO 19100 family of standards.

This document is not intended to replace the full and more detailed information of each of the ISO/TC 211 standards that are available for sale from individual national standards organizations and from the ISO Central Secretariat. [<http://www.iso.org/iso/home.htm>]

Best wishes for your productive use of this ISO/TC 211 Advisory Group on Outreach – Standards Guide.

Summer, 2009

*Henry Tom
Co-Chair,
ISO/TC 211 Advisory Group on Outreach*

*Charles Roswell
Technical Editor*

SCOPE OF ISO/TC 211

The scope of ISO/TC 211 is:

Standardization in the field of digital geographic information.

This work aims to establish a structured set of standards for information concerning objects or phenomena that are directly or indirectly associated with a location relative to the Earth.

These standards may specify, for geographic information, methods, tools and services for data management (including definition and description), acquiring, processing, analyzing, accessing, presenting and transferring such data in digital/electronic form between different users, systems and locations.

The work shall link to appropriate standards for information technology and data where possible, and provide a framework for the development of sector-specific applications using geographic data.

The overall objectives of ISO/TC 211 are:

- increase the understanding and usage of geographic information;
- increase the availability, access, integration, and sharing of geographic information;
- promote the efficient, effective, and economic use of digital geographic information and associated hardware and software systems;
- contribute to a unified approach to addressing global ecological and humanitarian problems.

BACKGROUND

The disciplines of cartography and geography, in response to technological innovations, have individually and collectively undergone significant changes during the past half-century. The 1950's witnessed the quantification of geography followed by the introduction of computers and modelling during the 1960's. The application of computer technology to cartography during the 1970's gave rise to automated/computer-assisted cartography, along with the adaptation of the mathematics of topology to computer cartography/geography around 1975 that led to the emergence of geographic information systems (GIS). From 1985 to 1995 saw the widespread development, use, and acceptance of GIS technology. During the period from 1995 to 2000, spatially enabled enterprise databases and the deployment of geographic information on the Internet rapidly positioned a new location-based technology as part of generic information technology.

The era of modern geographic standardization spanned the decade from the early 1980's to the early 1990's. Internationally, initial standardization efforts within cartography and geography were slow and arduous. National and international organizations were busy developing standards for the transfer/exchange of geographic data between computer systems. The technical development of such standards was limited to few national and regional user communities. There were no standards that had broad international support. By 1995, ISO/TC 211 developing international standards for spatial data and the Open GIS Consortium (OGC) developing computer interface specifications became highly visible and prominent players on the international geographic agenda.

Afterwards, ISO/TC 211 and the OGC formed a joint coordination group to leverage mutual development and minimize technical overlap. The OGC is submitting their specifications for ISO standardization via ISO/TC 211. The OGC, an industry consortium, has a conformance and testing program for the specifications they develop. There is also an OGC interoperability program for

developing specifications by rapid-prototyping software. This practical bottom up approach by industry and its vendors develops specifications as a result of implementation and interoperability scenarios. De jure standardization efforts represents a top down process that provides an over-arching and comprehensive framework for standardization that industry can use to incorporate and integrate OGC specifications.

The value of these initial international standardization efforts was to gain the international recognition and acceptance by the cartographic and geographic communities of the need and value of geographic standardization.

Unlike previous ISO technical committees, ISO/TC 211 has the unique distinction of beginning a programme of work that includes the concurrent development of an integrated set of twenty standards for geographic information. While the development of singular or stand-alone ISO standards occurs at a faster rate, the carefully developed ISO/TC 211 set of integrated standards advances the interoperability of its family of standards.

Achieving more interoperability requires a proactive coordination of spatial standards at both the abstract and implementation levels. Proactive cooperation among spatial standards activities of ISO/TC 211 and the OGC should also help to use available resources more efficiently by minimizing technical overlap, wherever this occurs. Such coordination and cooperation should lead to more market-relevant spatial standards, and could serve as a useful roadmap for all interested parties.

The increasing recognition for the value of spatial data and geographic information has spawned the entry of new players into the spatial standardization arena, both from within the ISO community and externally. This need for a structured division of labor and coordination resulted in the formation of a Joint Steering Group on Spatial Standardization and Related Interoperability, chaired by the ISO/TC 211 Chairman. Consequently, a new agenda emerged for international spatial standardization that includes traditional and new innovative applications across a spectrum of disciplines. For ISO/TC 211, these developments are resulting in new strategic directions such standards for location-based services and imagery.

The standardization programme for ISO/TC 211 is characterized by three generations:

- first generation – spatial data standards
- second generation – location based services and imagery standards
- third generation – information communities - frameworks for domain specific standards

STANDARDIZATION CHALLENGES FOR THE GEOSPATIAL COMMUNITY

LOCATION BASED SERVICES AND SPATIAL-ENABLEMENT

Since year 2000, many organizations collecting, processing, managing, disseminating and using geographic information have increasingly moved towards integrating Internet web services into their operational environment. Wireless and mobile applications, location-based products, services, and solutions initiated at the start of the new millennium with the promise of an increasing need for locational functionality via the Internet by not just the geographic community, but the world at large – but, this promise faltered. The global economic downturn during the first two years of the new millennium finally ran its course and the international economy began to recover and regain its earlier momentum.

The rise of the location-based services (LBS) industry is predicated upon the financial support of corporate telecommunications initiatives coupled with companies that can provide the technical expertise and required underlying geographic databases. The major issue of who pays for location-based services is a very important. The usual model of letting the consumer pay for LBS through some combination of a basic monthly rate along with usage charges may not be enough to attract and/or sustain such services. An additional variable will probably include an embedded subsidy by the telecommunication companies to reduce “churning” among customers. Churning is significant to the “bottom line” because it refers to customers switching from one mobile carrier to another because of some incentive in terms of price and/or service options being offered.

With the new millennium, IDC, the leading observer of the geospatial industry and market identified 6 major trends that are being realized in varying extents:

The Spatial Information Market (SIM) is more about spatially enabling business applications than building dedicated spatial applications.

Spatial technology has become much easier to integrate into business systems. One interesting result is that businesses can add spatial capabilities without help from traditional SIM vendors.

Spatial functions are secondary to other business functions within business-oriented systems.

New, standards-based SIM application development tools are now available from mainstream vendors such as Oracle, Microsoft, and IBM. Thus, the broad applications developer community will become a critical channel.

Because of the maturing Internet, geospatial capabilities can now be delivered as a service as well as traditional packaged software.

Spatial applications, whether single-purpose or broadly integrated, still require base-level spatial data. Spatially enabled business applications will also require accurate spatial data.

The renewed location-based mobile services (LBMS) is again on the rise. Many industry sectors within the market-place will benefit significantly from interoperable access to spatial information and services, including such areas as the travel and tourist industries, the mapping and routing industries, communications, utilities, transportation, national defense, agriculture, disaster management and public safety, inventory management, real and synthetic environmental modelling and gaming, and the emerging needs of electronic commerce for spatial information.

Location-based services, or location-based mobile services, are perhaps the most “high profile” of the emerging technologies to utilize geographic information. Many analysts foresee an enormous market in this field, one of them predicting, for example, that the market for tracking, route-finding and guiding, notification and alert services in North America and Western Europe will be huge. A whole string of partners is involved in a complex value –chain providing such services.

Location-based services are services (through a combination of hardware devices, communication networks – often wireless – and software applications) that access, provide or otherwise act upon location information. We distinguish between mobile position determination systems that determine the location of a mobile terminal and application-oriented location services, which exploit device location in some application service sought by a client.

The inclusion of GPS chips in wireless phones and the profusion of Personal Navigation Devices (PND), especially within cars is clearly dominating the general consumer market. But, the major dominance by Internet giants such as Microsoft, Yahoo, and Google over the traditional geospatial community in the provision of web based maps, location directions, satellite imagery has been quite a revelation to the geospatial sector. The smug attitude that only the geospatial community could provide such services, product, and even standards to support such commercialization was proven utterly false. Companies with little or no expertise in these areas entered the market and took it over – by the sheer force of numbers, they created the default de facto standards

Recently, there have been various developments that can directly affect the direction and future of the geospatial community. Underlying these developments, standards can play a significant role in shaping this direction and future.

INTERNET, GPS & MOBILE COMMUNICATIONS IMPACTS ON GEO-SPATIAL APPLICATIONS

These developments result from rapid changes in the movement of traditional mapping, geographic, and location-based services applications into the much broader digital technology market. Consumers of this mass-market digital technology are becoming more “spatially-aware” and sophisticated in their expectations of how the basic question of “where” is answered.

Such changes or “disruptions” are being reinforced by an open source software development movement in geospatial applications and intensified by the stunning appearance of mapping /imagery applications from major Internet companies and exposure of an open application program interface (API) to Google Maps, which is probably used by a million or more people and untold numbers of programmers that develop their own applications from the open Google API, Google Maps / Google Earth have been accompanied by others, such as, in the undeniable presence of Microsoft MapPoint and recent appearance of MSN Virtual Earth.

Standards and specifications developed by ISO/TC 211 and the Open Geospatial Consortium (OGC), with a name change from the Open GIS Consortium to reflect a broader constituency, have been adopted and implemented in the traditional mapping / geographic applications – and possibly in location-based-services applications.

But, what about the developers of open source software for geo-spatial applications - do they even know about these standards and specifications and if not, do they even care? Their widespread and ubiquitous use of such standards could integrate, advance, and shorten the time needed for software development significantly. In early 2006, the Open Source Geospatial Foundation was formed. A notable exception is the F/OSS, FOSS, or FLOSS (for Free/Libre/Open Source Software) for geo-spatial application: the GeoNetwork Opensource software implementing functional and cataloging capabilities for ISO 1915 Metadata Standard.

By virtual of the overwhelming number of users, Google and Microsoft totally control the mass market of consumers who have zero knowledge or no commitment to our “sacred” standards and specifications. These companies can instantaneously set de facto standards because their APIs are potentially supported by thousands of programmers and millions of users, who have free or very low

cost access to such applications. Initial queries to such companies regarding their adoptions of OGC specifications or ISO/TC 211 standards resulted in total ignorance of embarrassing proportions to these so called premier organizations for developing industry specifications and international standards.

In May 2006, for queries for map directions on the web had the following statistics:

Google - 26 million US visitors

Yahoo – 26.1 million visitors

Mapquest – 43.5 million visitors

In June 2006 – Google Earth software was downloaded by over 100 million people. If the Google API was adopted by for use by just 1 % of the Google downloads for Google Earth there would be around a million users – easily dominating the adoption of any traditional OGC specification or ISO standard. Undeniably, Google, Microsoft, and Yahoo are highly successful and provide maps, imagery and directions to the general public at large; they are clearing demonstrating that there is a market for location based services.

More recently, in July 2007, Tele Atlas, one of the two major companies in the world, providing high quality digital databases for car navigation, was bought for 2.8 billion USD by Tom Tom, a leading Personal Navigation Device (PND) company. The following sales statistics and projection provide an indication for the growing trend:

2006 17 million PND

2007 35 million PND

2010 83 million PND

In October 2007, Navteq, the other leading developer of digital databases for navigation, was bought for 8.1 billion USD by Nokia. Nokia had 36 % world market share mobile handsets

In 2006 with 346 million phone / mobile devices and will probably increase that number with the additional location based services capabilities added to their handsets.

Major players such as Google, Microsoft, Yahoo, Tom Tom and Nokia are doing what the geo-spatial community has not done: they have answered the question of where - for the masses on the Internet & for mobile devices such as PND and GPS enabled telephones and are now providing products and services based upon location. So what is the point? The point is that organizations such as ISO/TC 211 and OGC have been going along and developing standards. But, standards for whom? It would seem that ISO/TC 211 standards find their greatest acceptance with national mapping organizations and international institutional users that are comprised of professional and scientific societies and international non-governmental organizations such as the United Nations. OGC has many members, but it started out as an international industry consortium and its interface specifications are adopted by users with advanced geo-spatial applications. OGC has been working to bring geo-spatial applications into the “open architectures” of the Information and Communications Technology (ITC) industry

But, neither the standards / specifications developed by ISO/TC 211 or OGC currently seem to have widespread usage by the open software development movement or have been directly integrated into the open APIs that have been made available by Google Maps. The fact is, ISO/TC 211 and OGC seem to be developing standards and specifications only for internal usage within the geo-spatial community and even OGC APIs do not appear to be well known or not widely used in the general IT environment. This implication for the emergence of different sets of standards for consumers and for geo-spatial professionals poses significant challenges to ISO/TC 211 and the OGC.

So what can be done? We need to work at drawing the attention of the program managers, developers, and users of many of these Internet based applications and educating them about the

utility and advantages of using ISO/TC 211 standards and OGC specifications. If this can be done early on, then – there will be greater utility and access to traditional sources of geographic information that these applications will finally realize – they need. Moreover, there can be access, through these standards, to new sources of geographic information as well as new consumer applications.

But, even within the geo-spatial community, many fail to realize or recognize that ISO/TC 211 standards are fundamental to establishing and supporting the rapid development of national, regional, and global spatial data infrastructures. For example, the vast majority of all nations involved in the Global Spatial Data Infrastructure (GSDI) are developing countries that currently need basic spatial data standards for geographic information – high tech web-based interface specifications are fine, but premature for most developing countries, they need to be applied in conjunction with basic spatial data standards or applied afterwards. Hopefully, this viewpoint has helped to raise awareness for these rather significant issues and has also served as a call to arms.

Geo-spatial community, while accessing new data and applications, can also extend their own applications and data worldwide by: using these popular web mapping protocols & interfaces defined by these major players: but, in the end, these Internet Titans will have to access all the the world's efforts through national mapping organization and other organizations that produce geo-spatial data through the data standards developed ISO/TC 211.

To be balanced, the counterpoint is there may be some that feel that eventually, the Internet Titans will eventually need “traditional” standards for geographic information, however, much of this spatial data – represented by the core fundamental data sets of spatial data infrastructures (SDIs) may not be necessarily needed or relevant to these Titans, because the type of data they will need will be “yellow pages” data that is available and geo-coded by companies that provide commercial data. So, the precise digital cartographic boundaries for base maps, natural resources and the rest of these traditional geographic datasets may not be needed by the Titans for a long while, if needed at all. But, as these Titans are now fully engaged in capturing geo-referenced data at very large scale in urban and rural environments, that can be shared and integrated with “framework” datasets associated with spatial data infrastructures, in both directions, will certainly require a data interface between data gathered by commercial companies and spatial data infrastructures at all levels.

Regardless of which side of the debate one supports, the spatial data standards developed by ISO/TC 211 will be institutionalized in the long term by national mapping organizations, professional societies, and nongovernmental organizations such as the United Nations. Furthermore, ISO/TC 211 standards are becoming the frameworks for standardizing the technical domains of geo-spatial information communities.

In essence, the Class A Liaisons of ISO/TC 211 form the basic core of the user community of the standards developed by ISO/TC 211.

THE ISO/TC 211 USER COMMUNITY

ISO/TC 211 CLASS A LIAISONS

[Committee on Earth Observation Satellites/Working Group on Information Systems and Services \(CEOS/WGISS\)](#)

[Defence Geospatial Information Working Group \(DGIWG\)](#)

[EuroGeographics](#)

[European Commission Joint Research Centre \(JRC\)](#)

[European Space Agency \(ESA\)](#)

[European Spatial Data Research \(EuroSDR\)](#)

[Food and Agriculture Organization of the United Nations \(FAO/UN\)](#)

[Global Spatial Data Infrastructure \(GSDI\)](#)

[IEEE Geoscience and Remote Sensing Society](#)

[International Association of Geodesy \(IAG\)](#)

[International Association of Oil and Gas Producers \(OGP\)](#)

[International Cartographic Association \(ICA\)](#)

[International Civil Aviation Organization \(ICAO\)](#)

[International Federation of Surveyors \(FIG\)](#)

[International Hydrographic Bureau \(IHB\)](#)

[International Society for Photogrammetry and Remote Sensing \(ISPRS\)](#)

[International Steering Committee for Global Mapping \(ISCGM\)](#)

[Open Geospatial Consortium, Inc. \(OGC\)](#)

[Panamerican Institute of Geography and History \(PAIGH\)](#)

[Permanent Committee on GIS Infrastructure for Asia and the Pacific \(PCGIAP\)](#)

[Permanent Committee on Spatial Data Infrastructure for Americas \(PC IDEA\)](#)

[Scientific Committee on Antarctic Research \(SCAR\)](#)

[United Nations Economic Commission for Europe \(UN ECE\) Statistical Division](#)

[United Nations Economic Commission for Africa \(UN ECA\)](#)

[United Nations Geographic Information Working Group \(UNGIWG\)](#)

[United Nations Group of Experts on Geographical Names \(UNGEGN\)](#)

[Universal Postal Union \(UPU\)](#)

[World Meteorological Organization \(WMO\)](#)

Notably, there are several Class A Liaisons that have actively adopting and implementing ISO/TC 211 standards:

GLOBAL SPATIAL DATA INFRASTRUCTURE (GSDI)

The Global Spatial Data Infrastructure (GSDI) was defined at the 5th GSDI Conference in May 2001 as: “The Global Spatial Data Infrastructure is coordinated actions of nations and organizations that promotes awareness and implementation of complementary policies, common standards and effective mechanisms for the development and availability of interoperable digital geographic data and technologies to support decision making at all scales for multiple purposes.”

There are more than 50 nations developing national spatial data infrastructures. These guidelines highlight the importance of global standards, and point to the work of ISO as the basis upon which to build. The GSDI is now recognized as a Class A Liaison of ISO/TC 211.

GSDI is also working closely with the United Nations.

UN GEOGRAPHIC INFORMATION WORKING GROUP (UNGIWG)

The UN interest in geographic information is broad, and obviously runs the gamut of UN sectors. The UN Geographic Information Working Group (UNGIWG), comprised of 33 UN organizations, was established for the needs of peacekeeping actions, sustainable development and the eradication of poverty. This working group collaborates with ISO/TC 211 and uses ISO standards it has developed and has become a Class A Liaison of ISO/TC 211.

INFRASTRUCTURE FOR SPATIAL INFORMATION IN EUROPE (INSPIRE)

Recently, the European Commission has established an initiative known as Infrastructure for Spatial Information in Europe (INSPIRE) for around 30 national bodies in the European Union. The INSPIRE initiative aims to make harmonized and high quality geographic data and information readily available for formulating, implementing, monitoring and evaluating Community policy and for the citizen to access information about the environment, whether local, regional, national or international. INSPIRE recognizes ISO standards as a foundation for its work.

These and other global geographic organizations constitute the traditional user community for ISO/TC 211 standards. Currently, ISO/TC 211 has initiated its outreach activity to user communities to enable them to take advantage of the considerable international investment in the development of these standards.

Awareness of ISO/TC 211 standards is known within many but not all global geographic communities, however, adoption of ISO/TC 211 standards occurring among many user communities. The full realization of the benefits of ISO/TC 211 standards will only occur when they are implemented for many forms of human endeavor using geographic information.

As a strategic investment to ensure the long-term viability of ISO/TC 211 standards, there is a need for advocacy – to establish agreements between ISO/TC 211 and global organizations that will

recognize and institutionalize ISO/TC 211 standards as the foundation for the standardization of their geographic information.

*Henry Tom
Co-Chair,
ISO/TC 211 Advisory Group on Outreach
Summer, 2009*

SUMMARIES: PUBLISHED ISO/TC 211 STANDARDS

This document provides summaries of each of the published International Standards and Technical Specifications produced by ISO/TC 211. These summaries are in the form of slightly edited extracts of portions of the standards. The standards fall into several distinct groups, as listed below. The standards within each set are arranged such that general standards in the area are listed first and specific standards on related topics are grouped together.

STANDARDS THAT SPECIFY THE INFRASTRUCTURE FOR GEOSPATIAL STANDARDIZATION

- ISO 19101 Geographic information — Reference model
- ISO/TS 19103 Geographic information — Conceptual schema language
- ISO/TS 19104 Geographic information — Terminology
- ISO 19105 Geographic information — Conformance and testing
- ISO 19106 Geographic information — Profiles

STANDARDS THAT DESCRIBE DATA MODELS FOR GEOGRAPHIC INFORMATION

- ISO 19109 Geographic information — Rules for application schema
- ISO 19107 Geographic information — Spatial schema
- ISO 19137 Geographic information — Core profile of the spatial schema
- ISO 19123 Geographic information — Schema for coverage geometry and functions
- ISO 19108 Geographic information — Temporal schema
- ISO 19141 Geographic information — Schema for moving features
- ISO 19111 Geographic information — Spatial referencing by coordinates
- ISO 19112 Geographic information — Spatial referencing by geographic identifiers

STANDARDS FOR GEOGRAPHIC INFORMATION MANAGEMENT

- ISO 19110 Geographic information — Methodology for feature cataloguing
- ISO 19115 Geographic information — Metadata
- ISO 19113 Geographic information — Quality principles
- ISO 19114 Geographic information — Quality evaluation procedures
- ISO 19131 Geographic information — Data product specifications

ISO 19135 Geographic information — Procedures for item registration

ISO/TS 19127 Geographic information — Geodetic codes and parameters

ISO/TS 19138 Geographic information — Data quality measures

STANDARDS FOR GEOGRAPHIC INFORMATION SERVICES

ISO 19119 Geographic information — Services

ISO 19116 Geographic information — Positioning services

ISO 19117 Geographic information — Portrayal

ISO 19125-1 Geographic information — Simple feature access — Part 1: Common architecture

ISO 19125-2 Geographic information — Simple feature access — Part 2: SQL option

ISO 19128 Geographic information — Web map server interface

ISO 19132 Geographic information — Location based services — Reference model

ISO 19133 Geographic information — Location based services — Tracking and navigation

ISO 19134 Geographic information — Location base services — Multimodal routing and navigation

STANDARDS FOR ENCODING OF GEOGRAPHIC INFORMATION

ISO 19118 Geographic information — Encoding

ISO 6709 Standard representation of geographic point location by coordinates

ISO 19136 Geographic information — Geography Markup Language (GML)

ISO/TS 19139 Geographic information — Metadata — XML schema implementation

STANDARDS FOR SPECIFIC THEMATIC AREAS

ISO/TS 19101-2 Geographic information — Reference model — Part 2: Imagery

ISO 19115-2 Geographic information — Metadata — Part 2: Extensions for imagery and gridded data

INFRASTRUCTURE STANDARDS

This set of standards was developed in order to provide an infrastructure for the further standardization of geographic information. ISO 19101 describes the standardization environment within which the standardization of geographic information is expected to take place. ISO/TS 19103 identifies the conceptual schema language selected for characterization of geographic information and describes how that language is to be used. ISO/TS 19104 lays out a methodology for defining the terms needed in the area of geographic information. ISO 19105 specifies general principles for describing how geographic information products and services are expected to conform to the standards developed by ISO/TC 211. ISO 19106 specifies how profiles of the ISO/TC 211 standards are to be structured

This International Standard is a guide to structuring geographic information standards in a way that will enable the universal usage of digital geographic information. This reference model describes the overall requirements for standardization and the fundamental principles that apply in developing and using standards for geographic information. In describing these requirements and principles, this reference model provides a vision of standardization in which geographic information can be integrated with existing and emerging digital information technologies and applications.

This reference model uses concepts obtained from the ISO/IEC Open Systems Environment (OSE) approach for determining standardization requirements described in ISO/IEC TR 14252, the IEC Open Distributed Processing (ODP) Reference Model described in ISO/IEC 10746-1 and other relevant ISO standards and technical reports.

The focus of this family of standards is to:

- a) define the basic semantics and structure of geographic information for data management and data interchange purposes and
- b) define geographic information service components and their behaviour for data processing purposes.

Thus, the two major components of the reference model are the Domain Reference Model (Figure 1), which provides a high-level representation and description of the structure and content of geographic information, and the Architecture Reference Model (Figure 2), which describes the general types of services that will be provided by computer systems to manipulate geographic information and enumerates the service interfaces across which those services must interoperate.

Key elements of the Domain Reference Model are:

The *dataset* which contains:

- 1) *Features*, including feature attributes, feature relationships and feature operations.
- 2) *Spatial objects* that may describe the spatial aspects of *features*, or are complex data structures that associate values of attributes to individual positions within a defined space.
- 3) Descriptions of the *position of spatial objects* in space and time,

The *application schema*, which provides a description of the semantic structure of the dataset. The application schema also identifies the spatial object types and reference systems required to provide a complete description of geographic information in the dataset. Data quality elements and data quality overview elements are also included in the application schema.

The *metadata dataset* allows users to search for, evaluate, compare and order geographic data. It describes the administration, organization, contents and quality of geographic information in datasets. It may contain or reference the application schema for the geographic dataset. It may contain or reference the feature catalogue that contains the definitions of concepts used in the application schema. The structure of the metadata dataset is standardized in a metadata schema that is defined in ISO 19115.

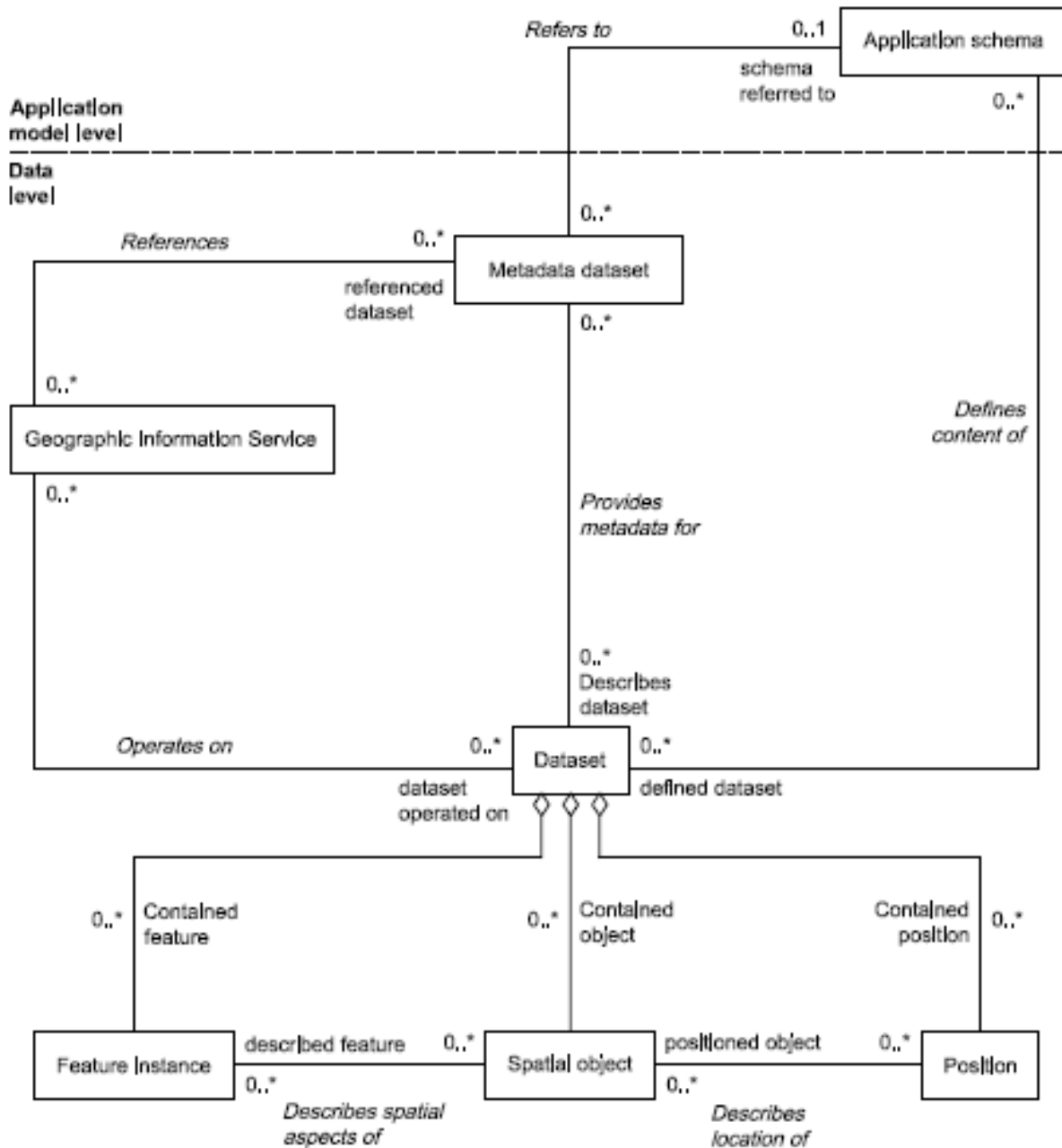

Figure 1 — High-level view of the ISO 19101 Domain reference model

The *Architectural reference model* (Figure 2) defines a structure for *geographic information services* and a method for identifying standardization requirements for those services. This model provides an understanding of what types of services are defined in the different standards in the ISO 19100 series of standards and distinguishes these services from other information technology services.

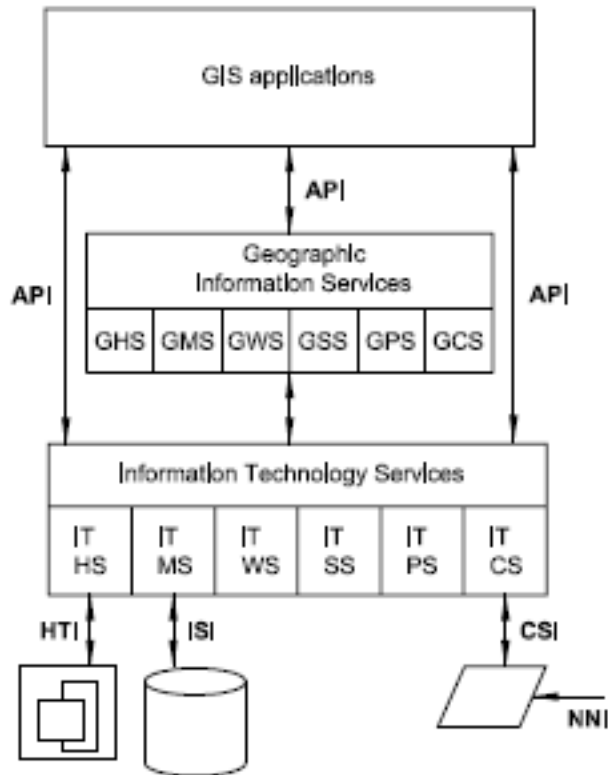

Figure 2 — The ISO 19101 Architectural reference model

Key

API	Application Programming Interface	G	Geographic
HTI	Human Technology Interface	IT	Information Technology
ISI	Information Services Interface	HS	Human Interaction Services
CSI	Communications Services Interface	MS	Model Management Services
NNI	Network to Network Interface	WS	Workflow/Task Services
		SS	System Management Services
		PS	Processing Services
		CS	Communication Services

ISO/TS 19103:2005 GEOGRAPHIC INFORMATION — CONCEPTUAL SCHEMA LANGUAGE

There are two aspects to this Technical Specification. The first step was to select a CSL that meets the requirements for rigorous representation of geographic information. This Technical Specification identifies the combination of the Unified Modeling Language (UML) static structure diagram with its associated Object Constraint Language (OCL) and a set of basic type definitions as the conceptual schema language for specification of geographic information. Secondly, this Technical Specification provides guidelines on how UML should be used to create geographic information and service models that are a basis for achieving the goal of interoperability.

The main technical content of this Technical Specification is found in Clause 6. An introduction to the general usage of UML (6.1 and 6.2) is followed by a description of classes and attributes based on general rules for UML (6.3 and 6.4). This Technical Specification specifies data types in 6.5, as standard UML does not prescribe the use of specific data types. More information on the use of UML models for describing geographic information is provided in 6.6, 6.7 and 6.8. The conventions for defining optional attributes and associations are described in 6.9. Naming rules are described in 6.10.

The data types defined in this Technical Specification are those that are usually defined by the development environment's data definition language. Each of these types can be represented in a variety of logically equivalent forms. The ones presented here are not meant to restrict the usage of other equivalent forms native to the chosen development environment. ISO/IEC 11404 presents an equivalent definition for most of the types and templates presented here.

The basic data types have been grouped into three categories.

- a) Primitive types: Fundamental types for representing values, examples are `CharacterString`, `Integer`, `Boolean`, `Date`, `Time`, etc.
- b) Implementation and collection types: Types for implementation and representation structures, examples are `Names Set` and `Records`, and types for representing multiple occurrences of other types, examples are `Set`, `Bag` and `Sequence`.
- c) Derived types: Measure types and units of measurement.

The basic types are defined as abstract types; appropriate representations will be defined by implementation and encoding mappings for the various subtypes.

This Technical Specification provides the guidelines for collection and maintenance of terminology in the field of geographic information. It establishes criteria for selection of concepts to be included in other standards concerning geographic information, which are developed by ISO/TC 211, specifies the structure of the terminological record, and describes the principles for definition writing.

This Technical Specification, along with a repository of GIS terminology in the form of a terminological database, is expected to be a central reference for the shared language between participants and users alike. It defines the criteria for including concepts in the vocabulary, specifies the terminological data to be recorded, and within the electronically processable repository introduces an initial set of concepts with definitions that will be subject to ongoing maintenance.

This Technical Specification describes the structure of entries and the types of terminological data that are to be recorded. In addition, it includes principles for definition writing as outlined in ISO 10241:1992 and ISO 704:2000.

Annex A lays down the guidelines for maintenance of a Terminology Repository.

Annex B is a list of terms that has been compiled from International Standards and Technical Specifications developed by ISO/TC 211 and other sources. Its purpose is to encourage consistency in the use and interpretation of geospatial terms. It is freely available for use by all interested people and organizations.

ISO 19105:2000 GEOGRAPHIC INFORMATION — CONFORMANCE AND TESTING

This International Standard specifies the framework, concepts and methodology for testing and criteria to be achieved to claim conformance to the family of ISO geographic information standards. It provides a framework for specifying abstract test suites (ATS) and for defining the procedures to be followed during conformance testing. Conformance may be claimed for data or software products or services or by specifications including any profile or functional standard.

A framework of an abstract test suite (ATS) is standardized for relevant standards in ISO/TC 211. The standardization of ATS requires international definition and acceptance of a common test methodology, together with appropriate test methods and procedures.

Test methods are also addressed in this International Standard; however, any organization contemplating the use of test methods defined in this International Standard should carefully consider the constraints on their applicability. Conformance testing does not include robustness testing, acceptance testing and performance testing, because the geographic information family of standards does not establish requirements for these areas.

The main body of this International Standard is structured as follows. The general framework of conformance including the definition of a conforming implementation appears in clause 5. Conformance testing methodology is described in clause 6. The possible test methods for testing conformance to the ISO geographic information standards are discussed in clause 7. The relationship between ATS and executable test suites (ETS) is presented in clause 8. A bibliography on conformance testing is given at the end. Guidelines for writing conformance clauses and associated templates are provided in annex A.

The ISO geographic information standards define a variety of models for describing, managing, and processing of geospatial data. Some of these standards create elements, others introduce structures and rules. Different user communities have different requirements for the extent they want to use or implement these elements and rules. Clearly identification and documentation of specific subsets of the ISO geographic information standards in a prescribed manner in conformance with these standards profiles are needed.

This International Standard is intended to define the concept of a profile of the ISO geographic information standards developed by ISO/TC 211 and to provide guidance for the creation of such profiles. Only those components of specifications that meet the definition of a profile contained herein can be established and managed through the mechanisms described in this International Standard. These profiles can be standardized internationally using the ISO standardization process. This document also provides guidance for establishing, managing, and standardizing at the national level (or in some other forum).

Two classes of conformance are defined in this International Standard.

Conformance class 1 is satisfied when a profile is established as a pure subset of the ISO geographic information standards, possibly together with other ISO standards.

Conformance class 2 allows profiles to include extensions within the context permitted in the base standard and permits the profiling of non-ISO geographic information standards as parts of profiles.

A profile may consist of a choice from the clauses, classes, options and parameters of base standards, or other profiles. This International Standard describes the procedures for the development of profiles. Registration is outside the scope of this International Standard. Examples of profiles are given in Annex B.

A profile

- a) may restrict the choice of options defined in base standards to the extent necessary to achieve the objective of the profile. A profile may retain base standard options as options of the profile;
- a) may not specify any requirements that would contradict or result in non-conformance to the base standards to which it refers;
- b) may contain conformance requirements which are more specific and limited in scope than those of the base standard to which it refers.

Thus, by definition, conformance to a profile implies conformance to the set of base standards to which it refers. However, conformance to that set of base standards does not necessarily imply conformance to the profile.

Clause 7 describes the purpose of profiles. Clause 8 describes how profiles reference base standards. Clause 9 describes the content of a profile and Clause 10 describes conformance requirements. Clause 11 describes the method for identifying profiles. Clause 12 describes the structure of documentation for profiles. Clause 13 describes the procedures for the preparation and adoption of profiles.

DATA MODEL STANDARDS

This set of standards builds on the domain reference model of ISO 19101. It provides a family of abstract conceptual schemas for describing the fundamental components of features as elements of geographic information. ISO 19109 specifies a general feature model for integrating these components into features and provides rules for doing so in an application schema. ISO 19107 specifies UML classes for representing the spatial characteristics of features as composites of geometric and/or topological primitives. ISO 19108 does the same for the temporal characteristics of features and also specifies classes for describing relevant temporal reference systems. ISO 19123 provides a schema for an alternative representation of spatial information as a coverage, in which non-spatial attributes are assigned directly to geometric objects rather than to features composed of such objects. ISO 19141 extends ISO 19107 to support the description of moving geometric objects. ISO 19137 provides a profile of ISO 19107 that is limited to describing features as simple geometric primitives of 0, 1, or 2 dimensions.

This International Standard defines rules for creating and documenting application schemas, including principles for the definition of features. An application schema provides the formal description of the data structure and content required by one or more applications. An application schema contains the descriptions of both geographic data and other related data. A fundamental concept of geographic data is the feature.

An application schema defines

- content and structure of data; and
- operations for manipulating and processing data by an application.

The purpose of an application schema is twofold:

- to provide a computer-readable data description defining the data structure, which makes it possible to apply automated mechanisms for data management; and
- to achieve a common and correct understanding of the data, by documenting the data content of the particular application field, thereby making it possible to unambiguously retrieve information from the data.

This International Standard does not standardize application schemas; it only defines rules for creating application schemas in a consistent manner (including the consistent definition of features) to facilitate the acquiring, processing, analysing, accessing, presenting and transferring of geographic data between different users, systems and locations.

An application schema is expressed in a conceptual schema language (CSL). Clause 7 includes a General Feature Model (GFM) expressed in UML that defines the concepts required to describe types of features. Feature type definition may be documented in feature catalogues. Such definitions may be used in an application schema. Other standards in the ISO 19100 series define reusable modules of conceptual schemas that may be integrated in an application schema. Clause 8 gives the principal rules for integrating these predefined modules into a conceptual schema in UML.

Subclause 7.3 uses the GFM (Figure 3) to identify and describe the concepts used to define features and how these concepts are related. The GFM is a model of the concepts required to classify a geographic view of the real world. UML has its own model of concepts (metamodel). As both the GFM and the UML metamodel deal with classification, the concepts are very similar. There is one big difference: the concepts in the GFM establish a basis for the classification of features, whereas the UML metamodel provides a basis for classification of any kind. The things we want to classify we call features; the relations between feature types are feature association types and inheritance. Feature types have properties that are feature attributes, feature operations and feature association roles. The GFM is a metamodel of feature types.

Besides a name and a description, a feature type is defined by its properties such as

- feature attributes;
- feature association roles characterizing the feature type; and
- defined behaviour of the feature type.

All these concepts are expressed as UML metaclasses in the GFM.

Additional concepts are

- feature associations between the feature type and itself or other feature types;
- generalization and specialization relationships to other feature types; and
- constraints on the feature type.

- how to map the feature types expressed in the concepts of the General Feature Model to the formalism used in the application schema; and
- how to use schemas defined in the other ISO 19100 series of International Standards.

The use of a formal language provides unambiguous and consistent representation of models, which facilitates implementations of applications. The normative part of this International Standard uses UML as the formal language for the description of application schema. The rules defined in Clause 8 are dependent on the UML formalism.

This International Standard provides conceptual schemas for describing and manipulating the spatial characteristics of geographic features. A feature is an abstraction of a real world phenomenon; it is a geographic feature if it is associated with a location relative to the Earth.

Vector data consists of geometric and topological primitives used, separately or in combination, to construct objects that express the spatial characteristics of geographic features. This International Standard deals only with vector data.

In the model defined in this International Standard, spatial characteristics are described by one or more spatial attributes whose value is given by a geometric object (GM_Object) or a topological object (TP_Object). Geometry provides the means for the quantitative description, by means of coordinates and mathematical functions, of the spatial characteristics of features, including dimension, position, size, shape, and orientation. The mathematical functions used for describing the geometry of an object depend on the type of coordinate reference system used to define the spatial position. Geometry is the only aspect of geographic information that changes when the information is transformed from one geodetic reference system or coordinate system to another. Figure 4 shows the geometry classes specified in this International Standard.

Topology deals with the characteristics of geometric figures that remain invariant if the space is deformed elastically and continuously — for example, when geographic data is transformed from one coordinate system to another. Within the context of geographic information, topology is commonly used to describe the connectivity of an n-dimensional graph, a property that is invariant under continuous transformation of the graph. Computational topology provides information about the connectivity of geometric primitives that can be derived from the underlying geometry. Figure 5 shows the topology classes specified in this international standard.

Spatial operators are functions and procedures that use, query, create, modify, or delete spatial objects. This International Standard defines the taxonomy of these operators in order to create a standard for their definition and implementation. The goals are to:

- a) Define spatial operators unambiguously, so that diverse implementations can be assured to yield comparable results within known limitations of accuracy and resolution.
- b) Use these definitions to define a set of standard operations that will form the basis of compliant systems, and, thus act as a test-bed for implementers and a benchmark set for validation of compliance.
- c) Define an operator algebra that will allow combinations of the base operators to be used predictably in the query and manipulation of geographic data.

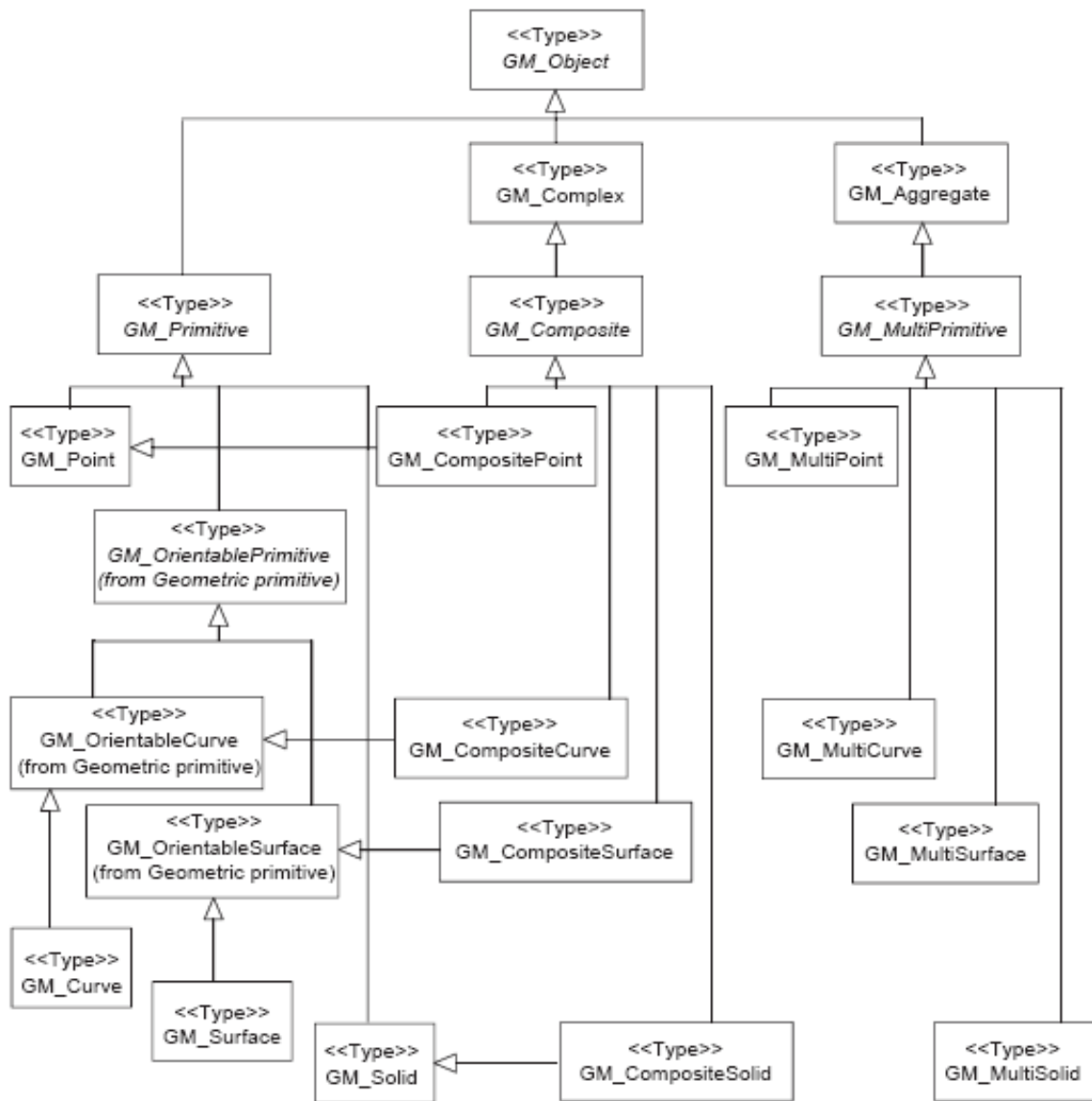

Figure 4 — Geometry basic classes with specialization relations

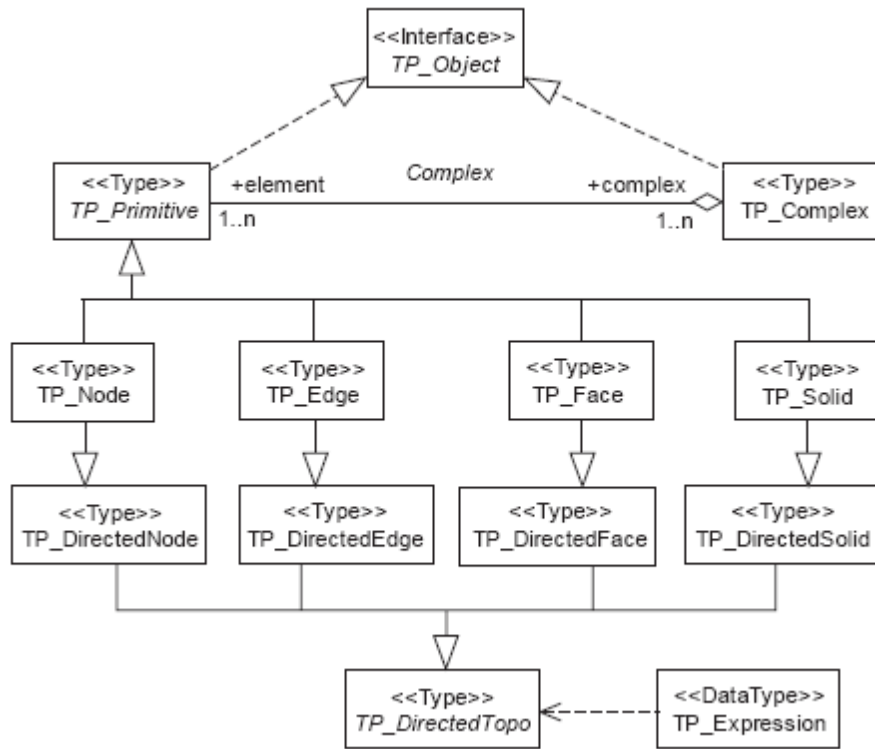

Figure 5 — Topological class diagram

ISO 19123:2005 – GEOGRAPHIC INFORMATION — SCHEMA FOR COVERAGE GEOMETRY AND FUNCTIONS

This International Standard defines a conceptual schema for the spatial characteristics of coverages. Coverages support mapping from a spatial, temporal or spatiotemporal domain to feature attribute values where feature attribute types are common to all geographic positions within the domain. A coverage domain consists of a collection of direct positions in a coordinate space that may be defined in terms of up to three spatial dimensions as well as a temporal dimension. Examples of coverages include rasters, triangulated irregular networks, point coverages and polygon coverages. Coverages are the prevailing data structures in a number of application areas, such as remote sensing, meteorology and mapping of bathymetry, elevation, soil and vegetation. This International Standard defines the relationship between the domain of a coverage and an associated attribute range. The characteristics of the spatial domain are defined whereas the characteristics of the attribute range are not part of this standard.

Historically, geographic information has been treated in terms of two fundamental types called vector data and raster data.

- “Vector data” deals with discrete phenomena, each of which is conceived of as a feature. The spatial characteristics of a discrete real-world phenomenon are represented by a set of one or more geometric primitives (points, curves, surfaces or solids). Other characteristics of the phenomenon are recorded as feature attributes. Usually, a single feature is associated with a single set of attribute values.
- “Raster data”, on the other hand, deals with real-world phenomena that vary continuously over space. It contains a set of values, each associated with one of the elements in a regular array of points or cells. It is usually associated with a method for interpolating values at spatial positions between the points or within the cells. Since this data structure is not the only one that can be used to represent phenomena that vary continuously over space, this International Standard uses the term “coverage,” adopted from the Abstract Specification of the Open GIS Consortium [1], to refer to any data representation that assigns values directly to spatial position. A coverage is a function from a spatial, temporal or spatiotemporal domain to an attribute range. A coverage associates a position within its domain to a record of values of defined data types.

A coverage is a feature that has multiple values for each attribute type, where each direct position within the geometric representation of the feature has a single value for each attribute type. A coverage is both a feature and a function. A coverage may represent a single feature or a set of features.

A coverage domain is a set of geometric objects described in terms of direct positions. It may be extended to all of the direct positions within the convex hull of that set of geometric objects. The direct positions are associated with a spatial or temporal coordinate reference system. Commonly used domains include point sets, grids, collections of closed rectangles, and other collections of geometric objects. The geometric objects may exhaustively partition the domain, and thereby form a tessellation such as a grid or a TIN. Point sets and other sets of non-conterminous geometric objects do not form tessellations. Coverage subtypes may be defined in terms of their domains.

The range of a coverage is a set of feature attribute values. It may be either a finite or a transfinite set. Coverages often model many associated functions sharing the same domain. Therefore, the value set is represented as a collection of records with a common schema.

Coverages are of two types. A discrete coverage has a domain that consists of a finite collection of geometric objects and the direct positions contained in those geometric objects. A discrete coverage maps each geometric object to a single record of feature attribute values. The geometric object and its associated record form a geometry value pair. A discrete coverage is thus a discrete or step function as opposed to a continuous coverage. Discrete functions can be explicitly enumerated as (input, output) pairs. A discrete coverage may be represented as a collection of ordered pairs of

independent and dependent variables. Each independent variable is a geometric object and each dependent variable is a record of feature attribute values.

EXAMPLE A coverage that maps a set of polygons to the soil type found within each polygon is an example of a discrete coverage.

A continuous coverage has a domain that consists of a set of direct positions in a coordinate space. A continuous coverage maps direct positions to value records.

EXAMPLE Consider a coverage that maps direct positions in San Diego County to their temperature at noon today. Both the domain and the range may take an infinite number of different values. This continuous coverage would be associated with a discrete coverage that holds the temperature values observed at a set of weather stations.

A feature attribute value may be of any data type. However, evaluation of a continuous coverage is usually implemented by interpolation methods that can be applied only to numbers or vectors. Other data types are almost always associated with discrete coverages.

The coverage schema is organized into seven packages with the inter-package dependencies shown in Figure 6. The Coverage Core package is documented in Clause 8, and each of the other packages is described in a separate clause as shown in Table 1.

Table 1 — Documentation of coverage geometry packages

Package	Clause
Coverage core	5
Discrete coverages	6
Thiessen polygon	7
Quadrilateral grid	8
Hexagonal grid	9
TIN	10
Segmented curve	11

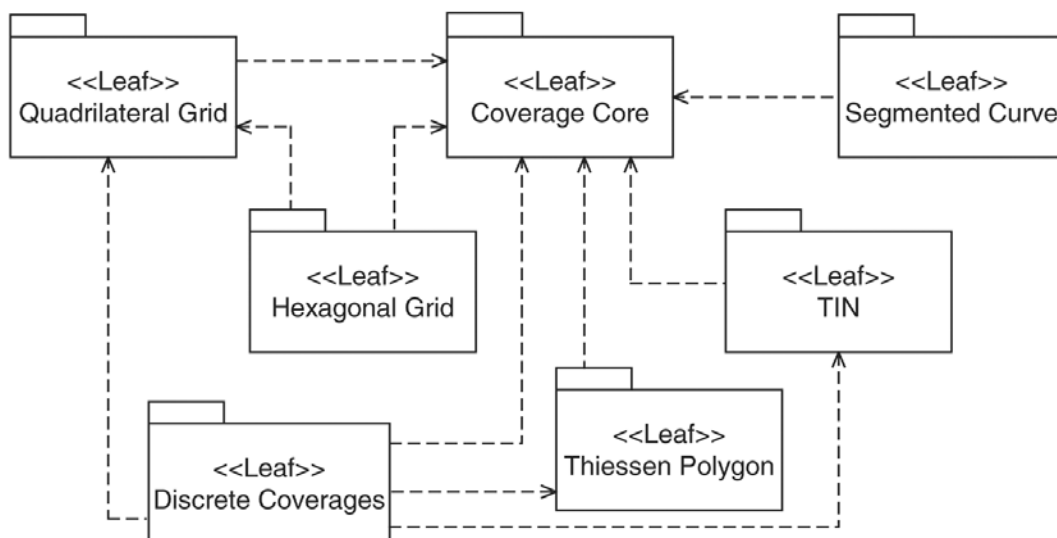

Figure 6 — Packages of the coverage schema

This International Standard defines the standard concepts needed to describe the temporal characteristics of geographic information as they are abstracted from the real world. Temporal characteristics of geographic information include feature attributes, feature operations, feature associations, and metadata elements that take a value in the temporal domain.

Temporal geometric and topological objects are used as values for the temporal characteristics of features and data sets. *TM_Object* (Figure 7) is an abstract class that has two subclasses. *TM_Primitive* is an abstract class that represents a non-decomposed element of geometry or topology of time. There are two subclasses of *TM_Primitive*. A *TM_GeometricPrimitive* provides information about temporal position. A *TM_TopologicalPrimitive* provides information about connectivity in time. A *TM_Complex* is an aggregation of *TM_Primitives*.

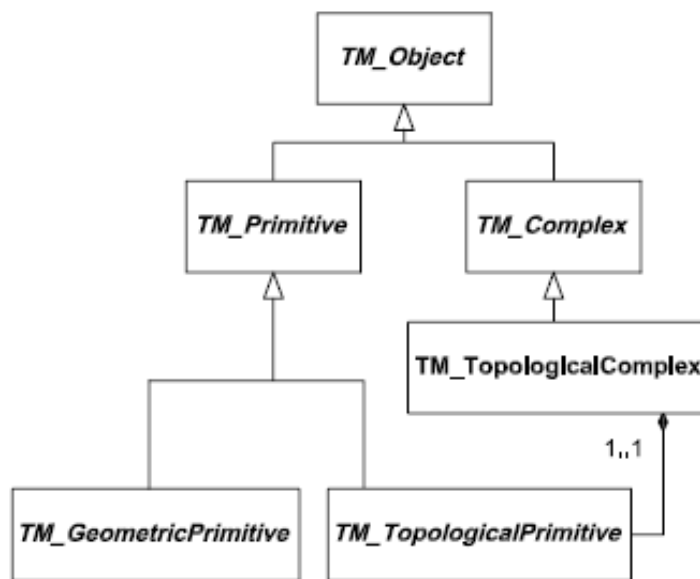

Figure 7 — Temporal objects

The two geometric primitives in the temporal dimension are the instant and the period. These primitives are defined analytically in the case of time measured on an interval scale, and analogically in the case of time measured on an ordinal scale. *TM_GeometricPrimitive* is an abstract class with two subclasses (Figure 8); *TM_Instant* represents an instant and *TM_Period* represents a period. *TM_GeometricPrimitive* inherits from *TM_Primitive* a dependency on the interface *TM_Order*, and also has a dependency on the interface *TM_Separation*.

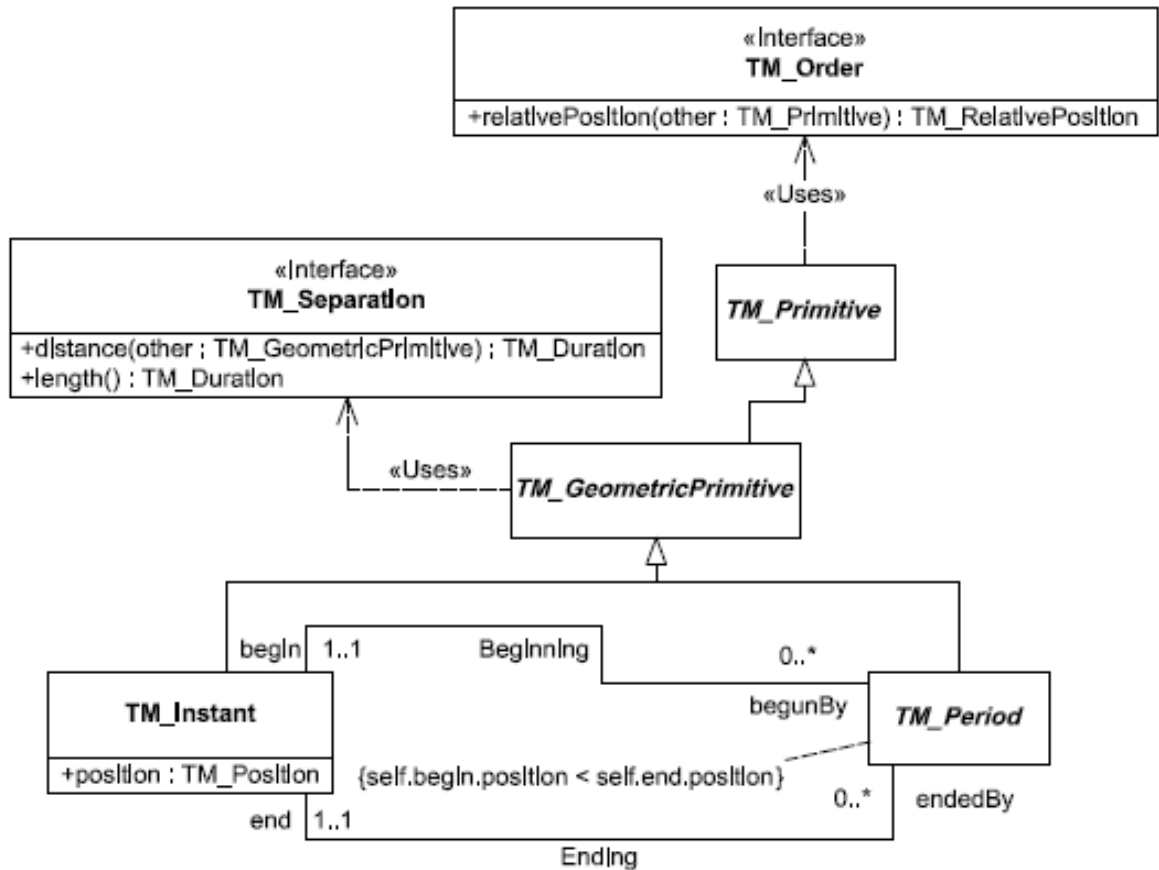

Figure 8 — Temporal geometric primitives

A topological primitive represents a single non-decomposable element of topology and its relationships to other topological primitives within a topological complex. The two topological primitives relevant for temporal information are the node, which is 0-dimensional, and the edge, which is one-dimensional. In the temporal schema, these are represented by two subclasses of `TM_TopologicalPrimitive`: `TM_Node` and `TM_Edge` (Figure 9). When an application includes information about temporal position as well as connectivity, a `TM_TopologicalPrimitive` may be associated with a `TM_GeometricPrimitive` of the same dimension.

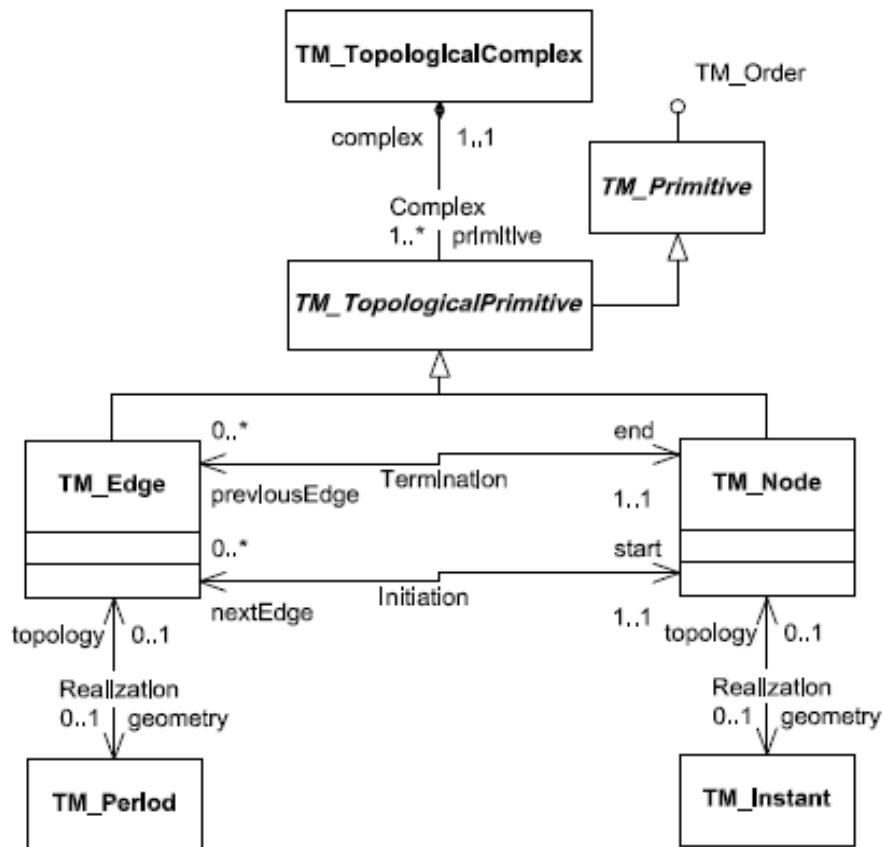

Figure 9 — Topology of time

A value in the time domain is a temporal position measured relative to a temporal reference system. ISO 8601 specifies the use of the Gregorian Calendar and 24-hour local or Coordinated Universal Time (UTC) for information interchange. This is the primary temporal reference system for use with geographic information. A different temporal reference system may be appropriate for some applications of geographic information. The Temporal reference system package includes three common types of temporal reference systems: calendars (used with clocks for greater resolution), temporal coordinate systems, and ordinal temporal reference systems (Figure 10).

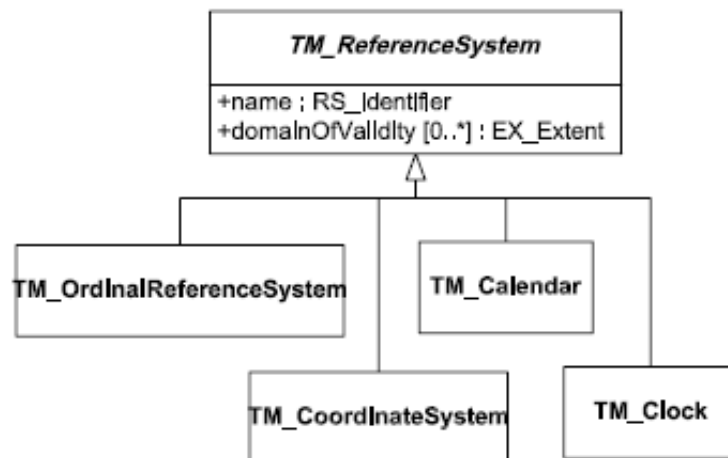

Figure 10 — Temporal reference systems

This International Standard specifies a conceptual schema that addresses moving features, i.e., features whose locations change over time. This schema includes classes, attributes, associations and operations that provide a common conceptual framework that can be implemented to support various application areas that deal with moving features.

This International Standard defines a standard method to describe the geometry of a feature that moves as a rigid body. Such movement has the following characteristics.

- a) The feature moves within any domain composed of spatial objects as specified in ISO 19107.
- b) The feature may move along a planned route, but it may deviate from the planned route.
- c) Motion may be influenced by physical forces, such as orbital, gravitational, or inertial forces.
- d) Motion of a feature may influence or be influenced by other features, e.g.:
 - 1) The moving feature might follow a predefined route (e.g., road), perhaps part of a network, and might change routes at known points (e.g., bus stops, waypoints).
 - 2) Two or more moving features may be “pulled” together or pushed apart (e.g., an airplane will be refuelled during flight, a predator detects and tracks a prey, refugee groups join forces).
 - 3) Two or more moving features may be constrained to maintain a given spatial relationship for some period (e.g., tractor and trailer, convoy).

This International Standard does not address other types of change to the feature. Because this International Standard is concerned with the geometric description of feature movement, it does not specify a mechanism for describing feature motion in terms of geographic identifiers. This is done, in part, in ISO 19133.

The schema specifies mechanisms to describe motion consisting of translation and/or rotation of the feature, but not including deformation of the feature. The schema is based on the concept of a one parameter set of geometries that may be viewed as a set of leaves or a set of trajectories, where a leaf represents the geometry of the moving feature at a particular value of the parameter (e.g., a point in time) and a trajectory is a curve that represents the path of a point in the geometry of the moving feature as it moves with respect to the parameter.

A moving feature can be modelled as a combination of movements. The overall motion can be expressed as the temporal path or trajectory of some reference point on the object (the “origin”), such as its center of gravity. Once the origin’s trajectory has been established, the position along the trajectory can be described using a linear reference system (as defined in ISO 19133). The “parameterization by length” for curves (as defined in ISO 19107) can be used as a simple linear reference if no other is available. The relationship between time (t) and measure value (m) can be represented as the graph of the $t \rightarrow m$ function in a plane with coordinates (t, m). This separation of the geometry of the path and the actual “time to position” function allows the moving feature to be tracked along existing geometry.

Figure 11 illustrates how the concepts of foliation, prism, trajectory, and leaf relate to one another. In this illustration, a 2D rectangle moves and rotates. Each representation of the rectangle at a given time is a leaf. The path traced by each corner point of the rectangle (and by each of its other points) is

a trajectory. The set of points contained in all of the leaves, and in all of the trajectories, forms a prism. The set of leaves also forms a foliation.

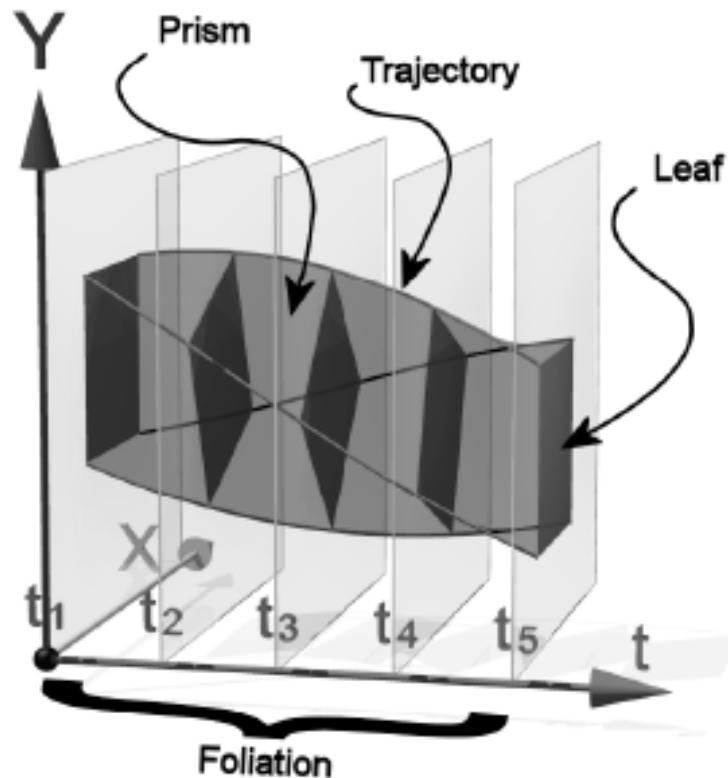

Figure 11 — Feature movement as foliation

These two object representations, of the path and the position along that path, give the general position of the moving feature. The other variable in describing the position of the feature is the rotation about the chosen reference point. To describe this, a local engineering coordinate system is established using the object reference point as its origin. The geometry of the feature is described in the engineering coordinate system and the real-world orientation of the feature is given by mapping of the local coordinate axes to the global coordinate system (the CRS of the trajectory of the reference point). This can be given as a matrix that maps the unit vectors of the local coordinate system to vectors in the global CRS.

If the global CRS and local CRS have the same dimension, then each point within the local CRS can be traced in time through the global CRS by combinations of these various mappings. The map would trace from time (t) to the measure (m) to a position on the reference point's path using the LRS. Then using the rotation matrix, the calculated offset from this point gives a direct position in the global CRS.

This means that the 'prism' of the moving feature (defined as all the points which part of the feature passes through) can be viewed (and calculated to whatever degree of accuracy needed) as a bundle of trajectories of points on the local engineering representation of the feature's geometry. If viewed in a 4 dimensional spatio-temporal coordinate system, the points on the feature at different times are different points. Then the pre-image of the prism (points on the trajectories augmented by a time coordinate) is a foliation, meaning that there is a complete and separate representation of the geometry of the feature for each specific time (called a "leaf"). These names come from a 3D metaphor of a book, where each page or leaf is a slice of time in the "folio."

The classes of the moving features schema form an inheritance hierarchy that has its source in the classes GM_Object and GM_Curve specified in ISO 19107 (Figure 12). This allows the subclasses specific to this schema to be used as feature attributes in compliance with the General Feature Model specified in ISO 19109. The second level of the hierarchy consists of a set of classes that describe a one-parameter geometry. These might be used to describe the movement of a feature with respect to any single variable such as pressure, temperature, or time. The third level specializes these classes to describe motion in time. The classes are specified fully in Clauses 6 and 7.

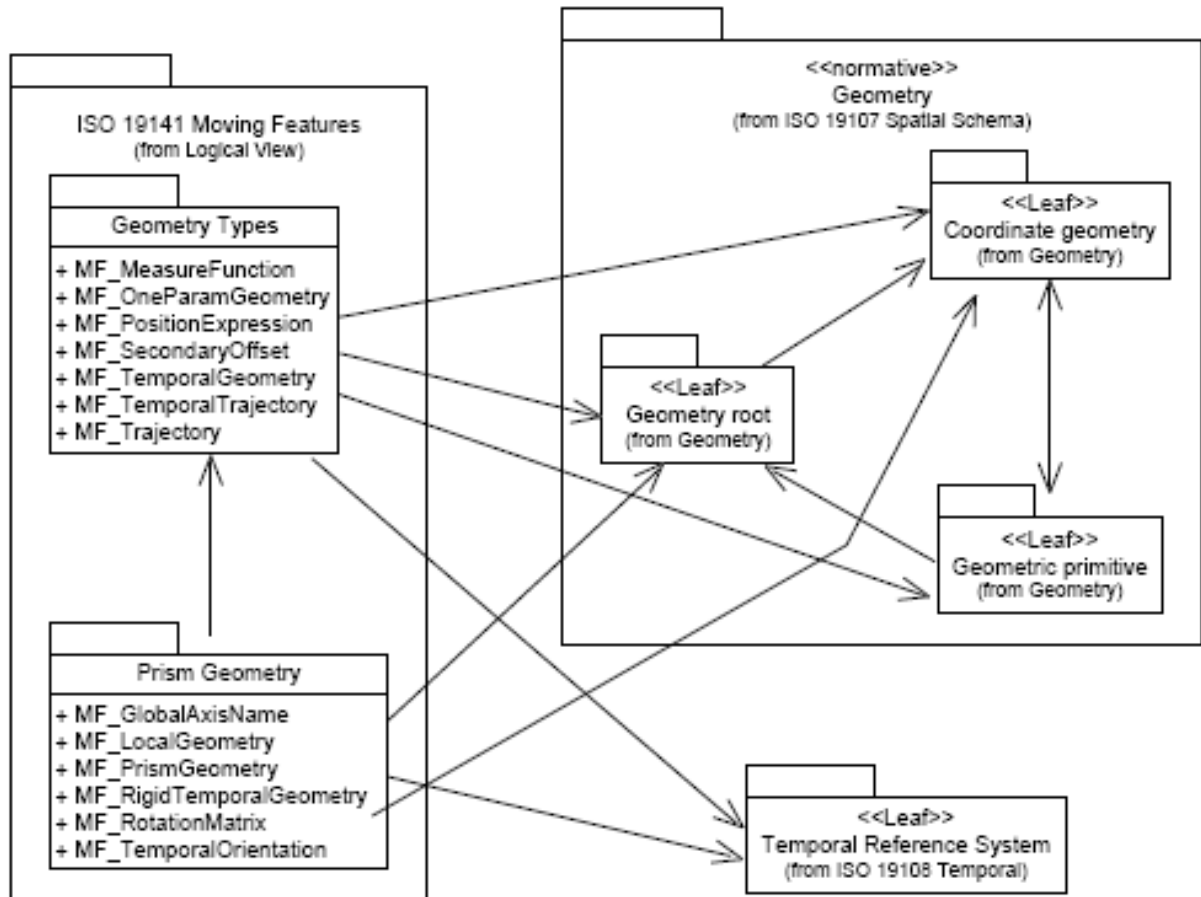

Figure 12 — Moving Feature Package

ISO 19137:2007 GEOGRAPHIC INFORMATION — CORE PROFILE OF THE SPATIAL SCHEMA

This International Standard defines a core profile of the spatial schema specified in ISO 19107 that specifies, in accordance with ISO 19106, a minimal set of geometric elements necessary for the efficient creation of application schemata.

This core profile is easy to understand and has a low cost of implementation. The profile is intentionally small and limited in order to increase the chance of gaining widespread market acceptance.

This International Standard supports data types for geometric primitives of 0, 1 and 2 dimensions. It satisfies the conformance test A.1.1.3 of ISO 19107. It is in conformance class 1 of ISO 19106.

This International Standard is limited to applications in which

- there is a 1:1 mapping between features and geometric primitives,
- all geometric primitives are referenced to a single coordinate reference system,
- all curves are composed of line segments, and
- all surfaces are composed of planar facets.

Abstract classes that are needed to provide compatibility with ISO 19107 are omitted from the simplified representation of the profile in Figure 13. Also, the inheritance relation between GM_Ring and GM_Object is not shown here. This International Standard uses no operations or interfaces from ISO 19107.

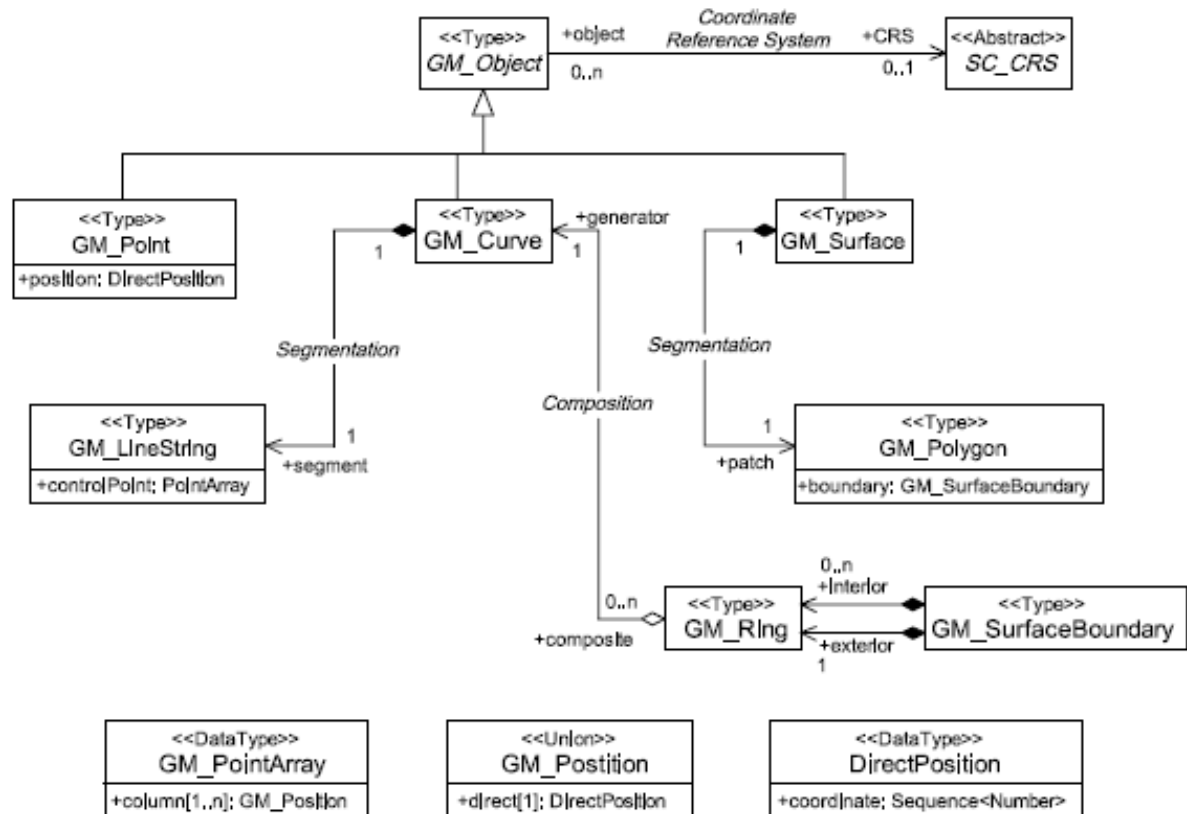

Figure 13 — A simplified, “flattened” view of the profile illustrating its structure

GEOGRAPHIC INFORMATION MANAGEMENT STANDARDS

This set of standards is also built on the domain reference model of ISO 19101, but, in contrast to the data model standards, which are focused on individual features and their characteristics, these standards are focused on the description of data sets containing information about one or, typically, many feature instances.

ISO 19110 specifies a methodology for developing catalogues containing definitions of feature types and their property types, including feature attributes, feature associations, and feature operations.

Geographic information contains spatial references which relate the features represented in the data to positions in the real world. Spatial references fall into two categories:

- those using coordinates;
- those based on geographic identifiers.

ISO 19111 provides a schema for describing the coordinate reference systems used to relate the position of geometric primitives to the earth or another object. ISO 19112 provides a general model for spatial referencing using geographic identifiers, as well as specifying the components of a spatial reference system and the essential components of a gazetteer.

ISO 19113 establishes a set of principles for describing and reporting the quality of geographic information. ISO 19114 specifies a set of procedures for evaluating and reporting the quality of geographic information. ISO 19115 provides a schema for and defines a set of metadata elements for describing the content of a geographic information data set. ISO 19131 describes requirements for specifying the characteristics expected of a geographic data product.

ISO 19135 specifies procedures for establishing and maintaining registers of identifiers and meanings assigned to items of geographic information. ISO/TS 19127 applies the principles of ISO 19111 and ISO 19135 to establish rules for the population and maintenance of registers of geodetic codes and parameter. ISO/TS 19138 extends ISO 19113 to define a set of data quality measures structured so that they can be maintained in a register established in conformance with ISO 19135.

ISO 19110:2005 GEOGRAPHIC INFORMATION — METHODOLOGY FOR FEATURE CATALOGUING

This International Standard defines the methodology for cataloguing feature types. It specifies how a classification of feature types is organized into a feature catalogue and presented to the users of a set of geographic data. This International Standard applies specifically to the cataloguing of feature types that are represented in digital form but its principles can be extended to the cataloguing of other forms of geographic data.

Geographic features are real world phenomena associated with a location relative to the Earth, about which data are collected, maintained, and disseminated. Feature catalogues defining the types of features, their operations, attributes, and associations represented in geographic data are indispensable to turning the data into usable information. Such feature catalogues promote the dissemination, sharing, and use of geographic data through providing a better understanding of the content and meaning of the data. Unless suppliers and users of geographic data have a shared understanding of the kinds of real world phenomena represented by the data, users will be unable to judge whether the data supplied are fit for their purpose.

Geographic features occur at two levels: instances and types. At the instance level, a geographic feature is represented as a discrete phenomenon that is associated with its geographic and temporal coordinates and may be portrayed by a particular graphic symbol. These individual feature instances are grouped into classes with common characteristics: feature types. It is recognized that geographic information is subjectively perceived and that its content depends upon the needs of particular applications. The needs of particular applications determine the way instances are grouped into types within a particular classification scheme.

A feature catalogue presents the abstraction of reality represented in one or more sets of geographic data as a defined classification of phenomena. The basic level of classification in a feature catalogue is the feature type. A feature catalogue is to be available in electronic form for any set of geographic data that contains features. A feature catalogue may also comply with the specifications of this International Standard independently of any existing set of geographic data.

A template for the representation of feature classification information is specified in Annex B. A feature catalogue prepared according to this template will document all of the feature types found in a given set of geographic data. The feature catalogue includes identification information as specified in Annex B. The feature catalogue also includes definitions and descriptions of all feature types contained in the data, including any feature attributes and feature associations contained in the data that are associated with each feature type, and optionally including feature operations that are supported by the data. To ensure predictability and comparability of feature catalogue content across different applications, it is recommended that the feature catalogue should include only the elements specified in Annex B. To maximize the usefulness of a feature catalogue across different applications, the use of a conceptual schema language to model feature catalogue information is recommended.

All feature types, feature attributes, feature associations, association roles, and feature operations included in a feature catalogue are identified by a name that is unique within that feature catalogue. Definitions of feature types, feature attributes, feature attribute listed values, feature associations, association roles, and feature operations are given in a natural language. Each feature type is identified by a name. Each feature type may also be identified by an alphanumeric code that is unique within the catalogue and it may have a set of aliases. The feature catalogue also includes, for each feature type, its feature operations and associated feature attributes, feature associations and association roles, if any. Feature operations, if any, are identified for each feature type. Feature attributes involved in each feature operation are specified as well as any feature types affected by the operation. In addition to the natural language definition, an operation may be formally specified in a functional language. Feature attributes, if any, are identified for each feature type. The definition includes a specified data type for values of the attribute. Each feature attribute may also be identified by an alphanumeric code that is unique within the catalogue. Feature-attribute listed values, if any, are labelled for each feature attribute. Feature associations, if any, are named. Each feature

association may also be identified by an alphanumeric code that is unique within the catalogue. The names and roles of the feature types that participate in the association are specified. Association roles, if any, are named. The name of the feature type that holds the role and the association in which it participates is specified.

ISO 19111:2007 GEOGRAPHIC INFORMATION — SPATIAL REFERENCING BY COORDINATES

This International Standard defines the conceptual schema for the description of spatial referencing by coordinates, optionally extended to spatio-temporal referencing and specifies the data elements, relationships and associated metadata required. It describes the minimum data required to define one-, two- and three-dimensional spatial coordinate reference systems with an extension to merged spatial-temporal reference systems. It describes the elements that are necessary to fully define various types of coordinate systems and coordinate reference systems applicable to geographic information. The subset of elements required is partially dependent upon the type of coordinates. This International Standard also includes optional fields to allow for the inclusion of non-essential coordinate reference system information. It also describes the information required to change coordinates from one coordinate reference system to another. The elements are intended to be both machine and human readable.

The traditional separation of horizontal and vertical position has resulted in coordinate reference systems that are horizontal (2D) and vertical (1D) in nature, as opposed to truly three-dimensional. It is established practice to define a three-dimensional position by combining the horizontal coordinates of a point with a height or depth from a different coordinate reference system. In this International Standard, this concept is defined as a compound coordinate reference system.

The concept of coordinates can be expanded from a strictly spatial context to include time. ISO 19108 describes temporal schema. Time can be added as a temporal coordinate reference system within a compound coordinate reference system. It is even possible to add two time-coordinates, provided the two coordinates describe different independent quantities.

In addition to describing a coordinate reference system, this International Standard provides for the description of a coordinate transformation or a coordinate conversion between two different coordinate reference systems. With such information, spatial data referred to different coordinate reference systems can be related to one specified coordinate reference system. This facilitates spatial data integration. Alternatively, an audit trail of coordinate reference system manipulations can be maintained.

A *coordinate* is one of n scalar values that define the position of a single point. A *coordinate tuple* is an ordered list of n coordinates that define the position of a single point. This International Standard requires that the coordinate tuple be composed of one, two or three spatial coordinates. The coordinates are mutually independent and their number is equal to the dimension of the coordinate space.

Coordinates are ambiguous until the system to which those coordinates are related has been fully defined. A *coordinate reference system* (CRS) defines the coordinate space such that the coordinate values are unambiguous. The order of the coordinates within the coordinate tuple and their unit(s) of measure are parts of the coordinate reference system definition.

A *coordinate set* is a collection of coordinate tuples referenced to the same coordinate reference system. A CRS identification or definition in accordance is associated with every coordinate tuple. If only one point is being described, the association is direct. For a coordinate set, one CRS identification or definition may be associated with the coordinate set and then all coordinate tuples in that coordinate set inherit that association.

This International Standard requires that a coordinate reference system be comprised of one coordinate system and one datum (see Figure 14).

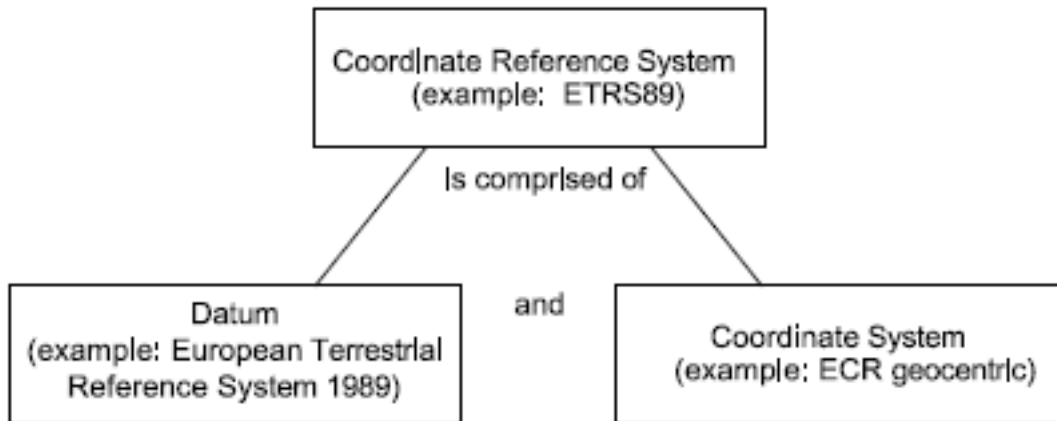

Figure 14 — Conceptual model of a coordinate reference system

The high level abstract model for spatial referencing by coordinates is shown in Figure 15. A coordinate transformation or coordinate conversion operates on coordinates, not on coordinate reference systems. Coordinate operation has been modelled in ISO 19107 by the operation “Transform” of the GM_Object class.

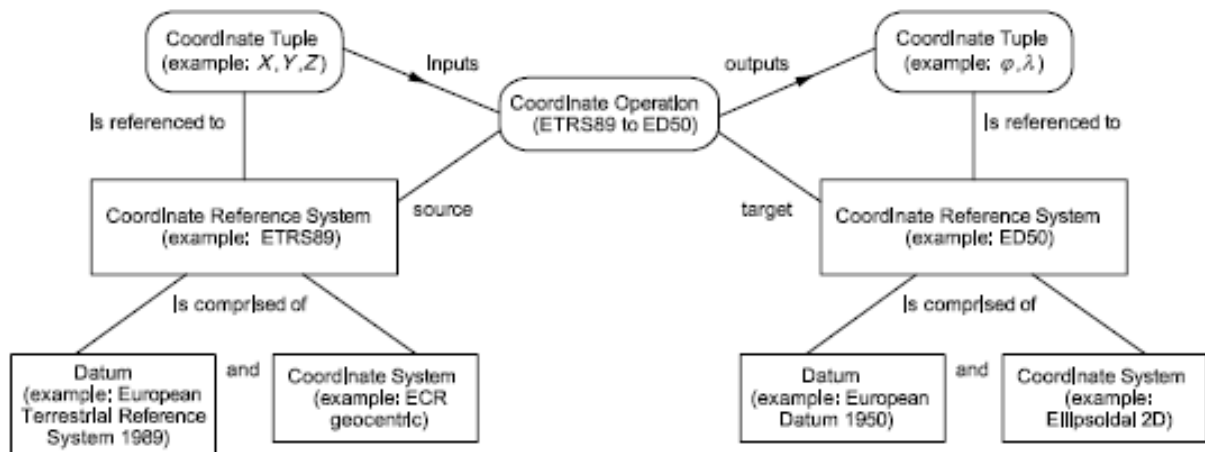

Figure 15 — Conceptual model for spatial referencing by coordinates

ISO 19112:2003 GEOGRAPHIC INFORMATION — SPATIAL REFERENCING BY GEOGRAPHIC IDENTIFIERS

This International Standard defines the conceptual schema for spatial references based on geographic identifiers. This type of spatial reference is sometimes called “indirect”.

This International Standard establishes a general model for spatial referencing using geographic identifiers, defines the components of a spatial reference system and defines the essential components of a gazetteer. Although this International Standard deals only with spatial referencing by geographic identifiers, a mechanism for recording complementary coordinate references is included.

Spatial reference systems using geographic identifiers are not based explicitly on coordinates but on a relationship with a location defined by a geographic feature or features. The relationship of the position to the feature may be as follows:

- a) containment, where the position is within the geographic feature, for example in a country;
- b) based on local measurements, where the position is defined relative to a fixed point or points in the geographic feature or features, for example at a given distance along a street from a junction with another street;
- a) loosely related, where the position has a fuzzy relationship with the geographic feature or features, for example adjacent to a building or between two buildings.

The purpose of this International Standard is to specify ways to define and describe systems of spatial references using geographic identifiers. However, it only covers the definition and recording of the referencing feature.

A spatial reference system using geographic identifiers comprises a related set of one or more location types, together with their corresponding geographic identifiers. These location types may be related to each other through aggregation or disaggregation, possibly forming a hierarchy.

A gazetteer is a directory of geographic identifiers describing location instances. It will contain additional information regarding the position of each location instance. It may include a coordinate reference, but it may also be purely descriptive. If it contains a coordinate reference, this will enable transformation from the spatial reference system using geographic identifiers to the coordinate reference system. If it contains a descriptive reference, this will be a spatial reference using a different spatial reference system with geographic identifiers, for example the postcode of a property. For any location type, there may be more than one gazetteer.

The relationships among spatial reference system, location and gazetteer are shown in Figure 16.

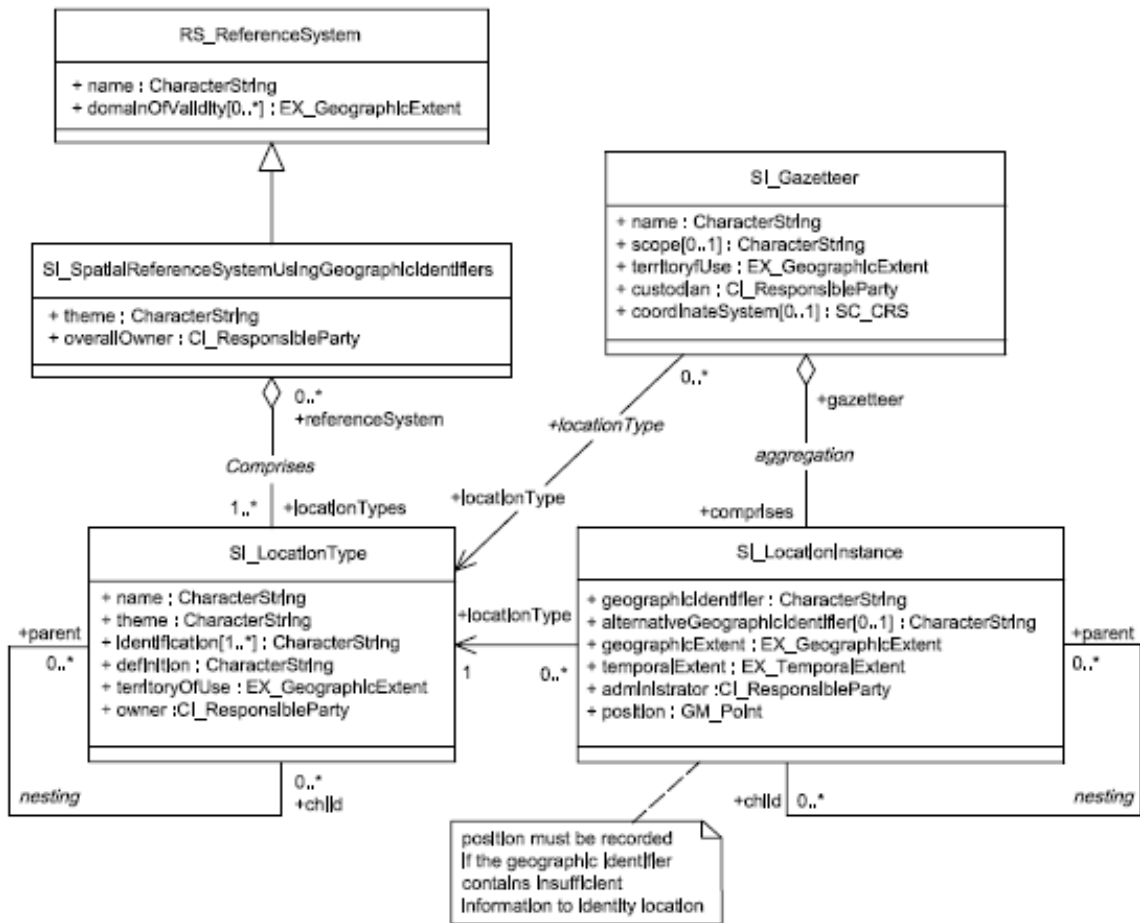

Figure 16 — UML model of spatial referencing using geographic identifiers

The objective of this International Standard is to provide principles for describing the quality for geographic data and concepts for handling quality information for geographic data.

The purpose of describing the quality of geographic data is to facilitate the selection of the geographic dataset best suited to application needs or requirements. Complete descriptions of the quality of a dataset will encourage the sharing, interchange and use of appropriate geographic datasets. A geographic dataset can be viewed as a commodity or product. Information on the quality of geographic data allows a data producer or vendor to validate how well a dataset meets the criteria set forth in its product specification and assists a data user in determining a product's ability to satisfy the requirements for their particular application.

This International Standard establishes the principles for describing the quality of geographic data and specifies components for reporting quality information. It also provides an approach to organizing information about data quality. This International Standard does not attempt to define a minimum acceptable level of quality for geographic data.

A quality description can be applied to a dataset series, a dataset or a smaller grouping of data located physically within the dataset sharing common characteristics so that its quality can be evaluated.

The quality of a dataset is described using two components:

Data quality elements, together with data quality subelements and the descriptors of a data quality subelement, describe how well a dataset meets the criteria set forth in its product specification and provide quantitative quality information.

Data quality overview elements provide general, non-quantitative information.

Figure 17 provides an overview of data quality information.

The following data quality elements, where applicable, are used to describe how well a dataset meets the criteria set forth in its product specification:

- completeness: presence and absence of features, their attributes and relationships;
- logical consistency: degree of adherence to logical rules of data structure, attribution and relationships (data structure can be conceptual, logical or physical);
- positional accuracy: accuracy of the position of features;
- temporal accuracy: accuracy of the temporal attributes and temporal relationships of features;
- thematic accuracy: accuracy of quantitative attributes and the correctness of non-quantitative attributes and of the classifications of features and their relationships.

Additional data quality elements may be created to describe a component of the quantitative quality of a dataset not addressed in this International Standard.

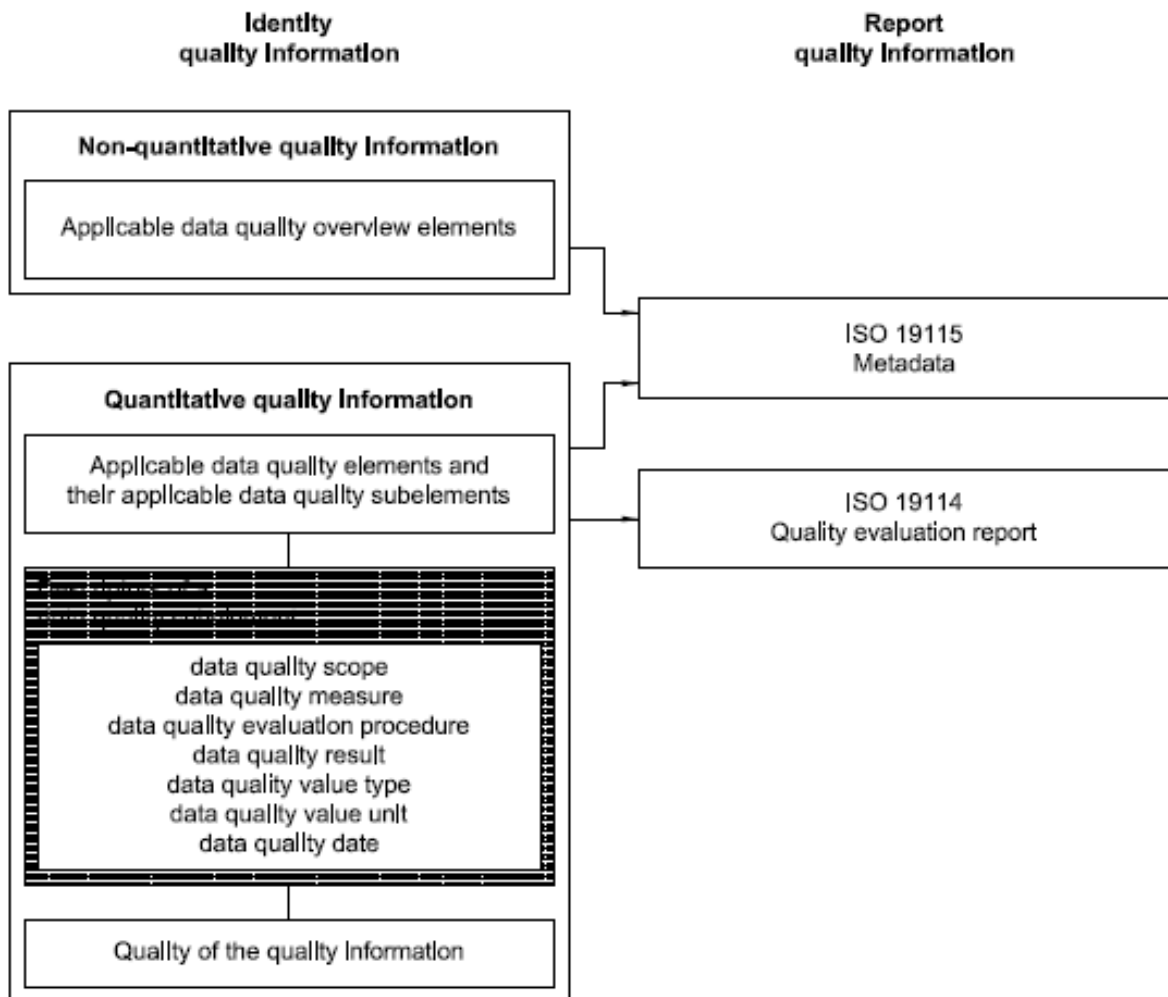

Figure 17 — An overview of data quality information

The following data quality overview elements where applicable is used to describe the non-quantitative quality of a dataset:

- purpose;
- usage;
- lineage.

ISO 19114:2003 GEOGRAPHIC INFORMATION — QUALITY EVALUATION PROCEDURES

This International Standard provides a framework of procedures for determining and evaluating quality that is applicable to digital geographic datasets, consistent with the data quality principles defined in ISO 19113. It also establishes a framework for evaluating and reporting data quality results, either as part of data quality metadata only, or also as a quality evaluation report.

For the purpose of evaluating the quality of a dataset, clearly defined procedures must be used in a consistent manner. This enables data producers to express how well their product meets the criteria set forth in its product specification and enables data users to establish the extent to which a dataset meets their requirements. The quality of a dataset is described using two components: a quantitative component and a non-quantitative component. The objective of this International Standard is to provide guidelines for evaluation procedures of quantitative quality information for geographic data in accordance with the quality principles described in ISO 19113. It also offers guidance on reporting quality information.

This International Standard recognizes that a data producer and a data user may view data quality from different perspectives. Conformance quality levels can be set using the data producer's product specification or a data user's data quality requirements. If the data user requires more data quality information than that provided by the data producer, the data user may follow the data producer's data quality evaluation process flow to get the additional information. In this case, the data user requirements are treated as a product specification for the purpose of using the data producer process flow.

The quality evaluation procedures described in this International Standard, when applied in accordance with ISO 19113, provide a consistent and standard manner to determine and report the quality information in a dataset.

The process for evaluating data quality (Figure 18) is a sequence of steps to produce and report a data quality result. A quality evaluation process consists of the application of quality evaluation procedures to specific dataset-related operations performed by the dataset producer and the dataset user.

A data quality evaluation procedure is accomplished through the application of one or more data quality evaluation methods. Data quality evaluation methods are divided into two main classes: direct and indirect. Direct methods determine data quality through the comparison of the data with internal and/or external reference information. Indirect methods infer or estimate data quality using information on the data, such as lineage.

Quantitative quality results are reported as metadata in compliance with ISO 19115, which contains the related model and data dictionary. There are two conditions under which a quality evaluation report is to be produced:

- a) when data quality results reported as metadata are only reported as pass/fail;
- b) when aggregated data quality results are generated.

The report is required in the latter condition to explain how aggregation was done and how to interpret the meaning of the aggregate result. However, a quality evaluation report may be created at any other time (such as to provide more detail than reported as metadata) but a quality evaluation report cannot be used in lieu of reporting as metadata.

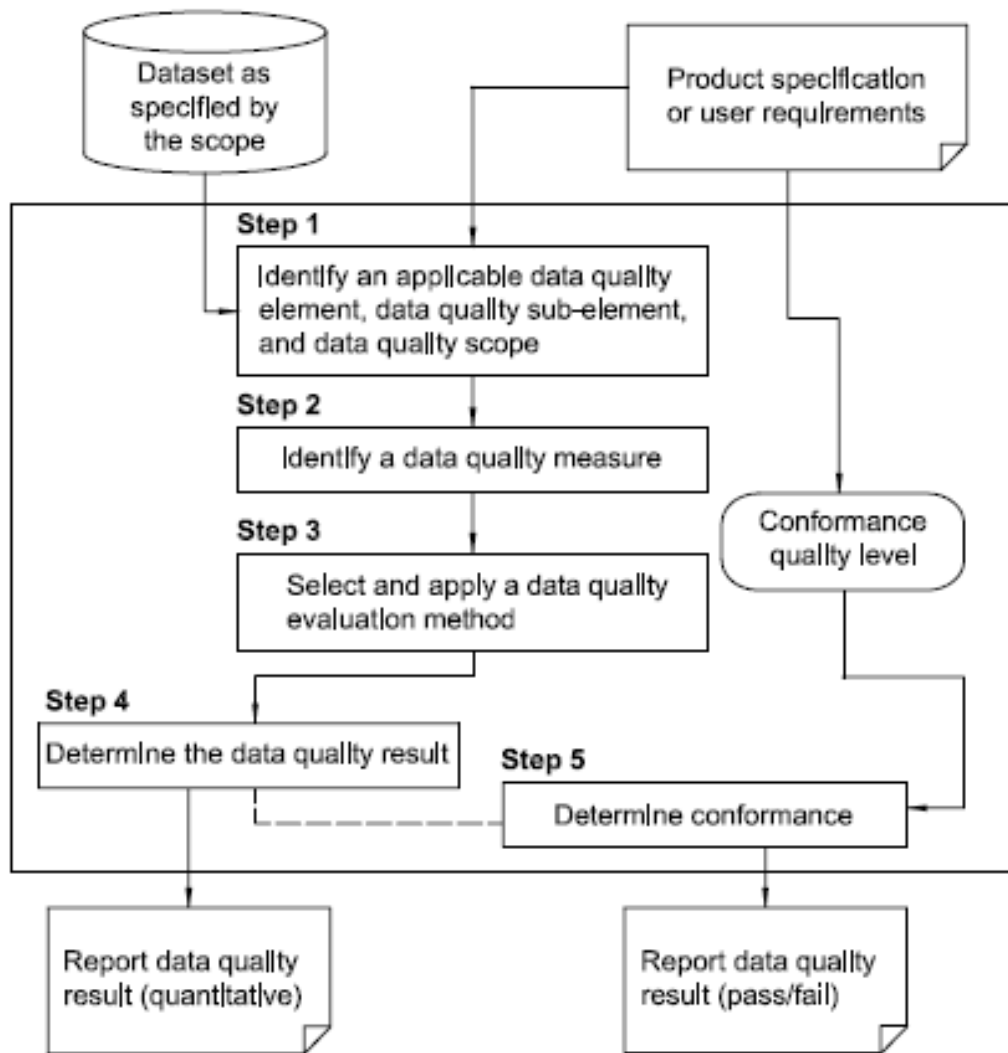

Figure 18 — Evaluating and reporting data quality results

The objective of this International Standard is to provide a structure for describing digital geographic data.

This International Standard defines metadata elements, provides a schema and establishes a common set of metadata terminology, definitions, and extension procedures. This International Standard defines the schema required for describing geographic information and services. It provides information about the identification, the extent, the quality, the spatial and temporal schema, spatial reference, and distribution of digital geographic data.

This International Standard defines:

- mandatory and conditional metadata sections, metadata entities, and metadata elements;
- the minimum set of metadata required to serve the full range of metadata applications (data discovery, determining data fitness for use, data access, data transfer, and use of digital data);
- optional metadata elements – to allow for a more extensive standard description of geographic data, if required;
- a method for extending metadata to fit specialized needs.

Metadata is applicable to independent datasets, aggregations of datasets, individual geographic features, and the various classes of objects that compose a feature. Metadata is to be provided for geographic datasets and may, optionally, be provided for aggregations of datasets, features, and attributes of features. Metadata is composed of one or more Metadata Sections (UML Packages) containing one or more Metadata Entities (UML classes).

In this International Standard, metadata for geographic data is presented in UML Packages. Each package contains one or more entities (UML Classes), which can be specified (subclassed) or generalized (superclassed). Entities contain elements (UML class attributes) which identify the discrete units of metadata. Entities may be related to one or more other entities. Entities can be aggregated and repeated as necessary to meet: (1) the mandatory requirements stated in this International Standard; (2) additional user requirements. Figure 19 illustrates the layout of the packages. The metadata is fully specified in the UML model diagrams and data dictionary for each package, which can be found in Annexes A and B respectively.

This International Standard defines an extensive set of metadata elements; typically only a subset of the full number of elements is used. However, it is essential that a basic minimum number of metadata elements be maintained for a dataset. Listed are the core metadata elements required to identify a dataset, typically for catalogue purposes. This list contains metadata elements answering the following questions: “Does a dataset on a specific topic exist (‘what’)?”, “For a specific place (‘where’)?”, “For a specific date or period (‘when’)?” and “A point of contact to learn more about or order the dataset (‘who’)?”. Using the recommended optional elements in addition to the mandatory elements will increase interoperability, allowing users to understand without ambiguity the geographic data and the related metadata provided by either the producer or the distributor. Dataset metadata profiles of this International Standard include this core.

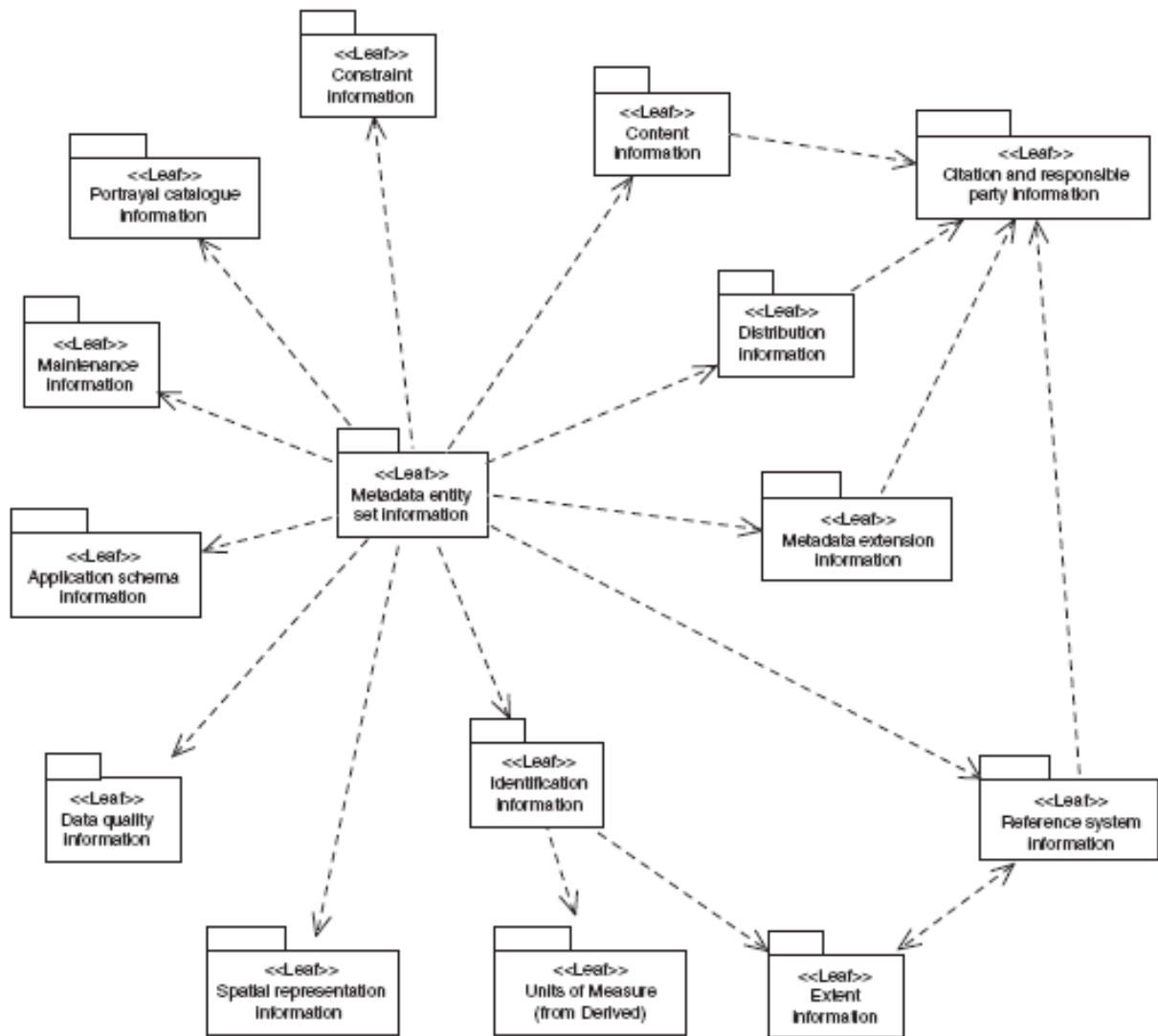

Figure 19 — Metadata packages

Listed below (Table 2) are the core metadata elements (mandatory and recommended optional) required for describing a dataset. An “M” indicates that the element is mandatory. An “O” indicates that the element is optional. A “C” indicates that the element is mandatory under certain conditions.

Table 2 – Core metadata for geographic datasets

Dataset title (M) (MD_Metadata > MD_DataIdentification.citation > CI_Citation.title)	Spatial representation type (O) (MD_Metadata > MD_DataIdentification.spatialRepresentationType)
Dataset reference date (M) (MD_Metadata > MD_DataIdentification.citation > CI_Citation.date)	Reference system (O) (MD_Metadata > MD_ReferenceSystem)
Dataset responsible party (O) (MD_Metadata > MD_DataIdentification.pointOfContact > CI_ResponsibleParty)	Lineage (O) (MD_Metadata > DQ_DataQuality.lineage > LI_Lineage)
Geographic location of the dataset (by four coordinates or by geographic identifier) (C) (MD_Metadata > MD_DataIdentification.extent > EX_Extent > EX_GeographicExtent > EX_GeographicBoundingBox or EX_GeographicDescription)	On-line resource (O) (MD_Metadata > MD_Distribution > MD_DigitalTransferOption.onLine > CI_OnlineResource)
Dataset language (M) (MD_Metadata > MD_DataIdentification.language)	Metadata file identifier (O) (MD_Metadata.fileIdentifier)
Dataset character set (C) (MD_Metadata > MD_DataIdentification.characterSet)	Metadata standard name (O) (MD_Metadata.metadataStandardName)
Dataset topic category (M) (MD_Metadata > MD_DataIdentification.topicCategory)	Metadata standard version (O) (MD_Metadata.metadataStandardVersion)
Spatial resolution of the dataset (O) (MD_Metadata > MD_DataIdentification.spatialResolution > MD_Resolution.equivalentScale or MD_Resolution.distance)	Metadata language (C) (MD_Metadata.language)
Abstract describing the dataset (M) (MD_Metadata > MD_DataIdentification.abstract)	Metadata character set (C) (MD_Metadata.characterSet)
Distribution format (O) (MD_Metadata > MD_Distribution > MD_Format.name and MD_Format.version)	Metadata point of contact (M) (MD_Metadata.contact > CI_ResponsibleParty)
Additional extent information for the dataset (vertical and temporal) (O) (MD_Metadata > MD_DataIdentification.extent > EX_Extent > EX_TemporalExtent or EX_VerticalExtent)	Metadata date stamp (M) (MD_Metadata.dateStamp)

This International Standard describes requirements for the specification of geographic data products, based upon the concepts of other ISO 19100 International Standards. It describes the content and structure of a data product specification. It also provides help in the creation of data product specifications, so that they are easily understood and fit for their intended purpose.

A data product specification is a detailed description of a dataset or dataset series together with additional information that will enable it to be created, supplied to and used by another party. It is a precise technical description of the data product in terms of the requirements that it will or may fulfil. It forms the basis for producing or acquiring data. It may also help potential users to evaluate the data product to determine its fitness for use by them.

Information from the data product specification may be used in the creation of metadata for a particular dataset that is created in conformance with that data product specification. However, information contained in a data product specification is different from that contained in metadata. Metadata provides information about a particular physical dataset; the data product specification only defines how the dataset should be. For various reasons, compromises may need to be made in the implementation. The metadata associated with the product dataset should reflect how the product dataset actually is. The relationship between a data product specification and metadata is described more fully in Annex B.

A data product specification may be created and used on different occasions, by different parties and for different reasons. It may, for example, be used for the original process of collecting data as well as for products derived from already existing data. It may be created by producers to specify their product or by users to state their requirements.

It is not necessary for a data product specification to specify the production process, but only the resulting data product. Nevertheless, it may include production and maintenance aspects if judged necessary to describe the data product.

A data product specification contains major sections covering the following aspects of the data product:

- Overview — Clause 7;
- Specification scopes — Clause 8;
- Data product identification — Clause 9;
- Data content and structure — Clause 10;
- Reference systems — Clause 11;
- Data quality — Clause 12
- Metadata — Clause 18.

A data product specification may also contain sections covering the following aspects of the data product:

- Data capture — Clause 13;
- Data maintenance — Clause 14;
- Portrayal — Clause 15;
- Additional information — Clause 17.

The minimum description of a data product contains the mandatory elements within each section.

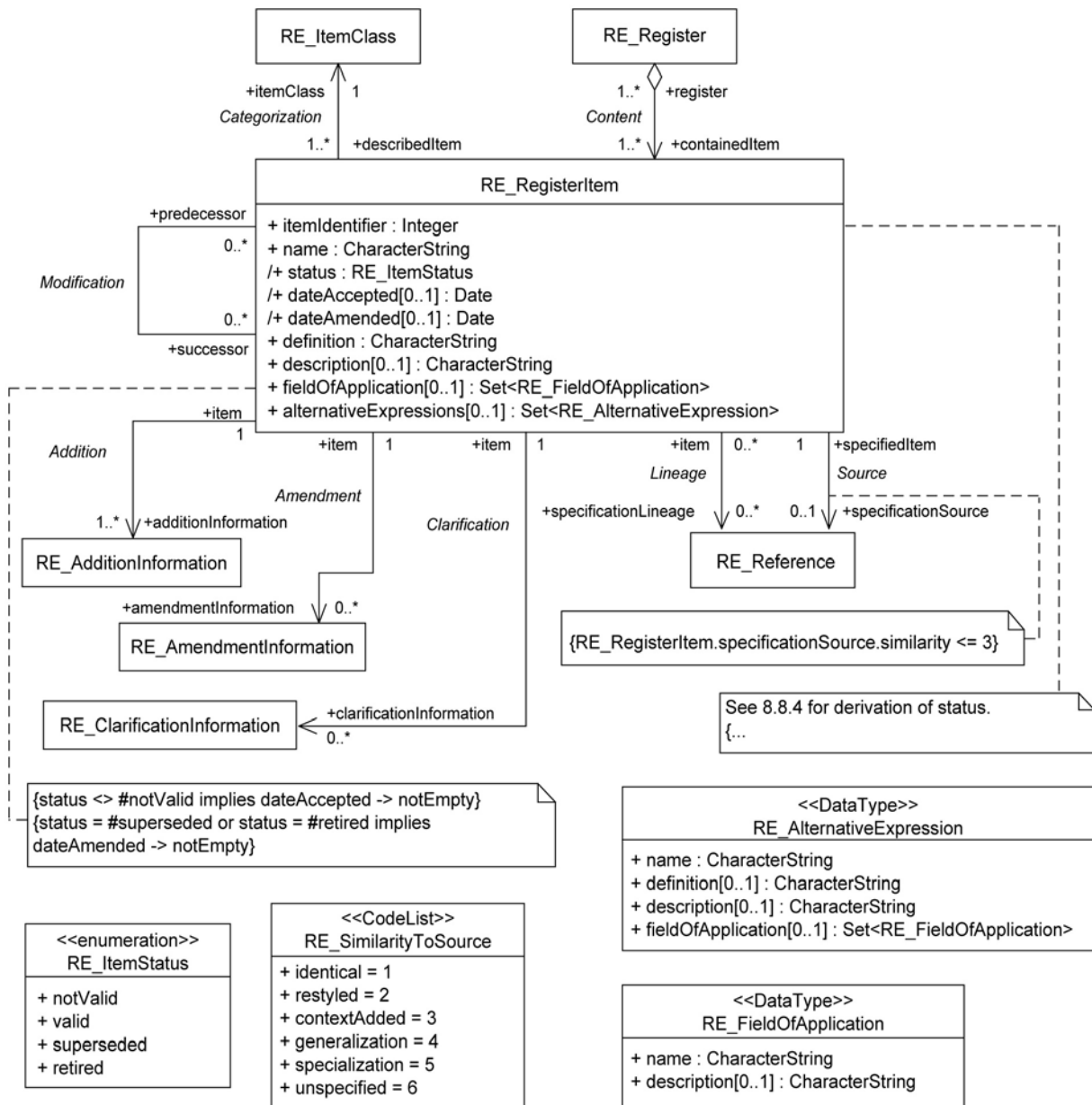

Figure 21 — RE_RegisterItem

ISO/TS 19127:2005 GEOGRAPHIC INFORMATION — GEODETIC CODES AND PARAMETERS

This Technical Specification defines rules for the population and maintenance of registers of geodetic codes and parameters and identifies the data elements, in compliance with ISO 19111 and ISO 19135, required within these registers. Recommendations for the use of the registers, the legal aspects, the applicability to historic data, the completeness of the registers, and a mechanism for maintenance are specified by the registers themselves.

The ISO geodetic registry network is defined as:

- a) The ISO register of geodetic registers. This principal register holds a set of items that describe the subregisters described in b) and c);
- b) The ISO register of geodetic codes and parameters. This subregister contains coordinate reference system data and coordinate transformation data that conform to ISO 19111 and are international in geographic extent of application, widely used, and well defined. See Tables B.1, B.2 and B.3 for requirements for entries in the ISO register;
- c) External subregisters of geodetic codes and parameters. These subregisters contain coordinate reference system data and coordinate transformation data that conform to ISO 19111. See Tables B.1, B.2 and B.3 for requirements for entries in the external subregisters of geodetic codes and parameters.

Figure 22 illustrates the ISO geodetic registry network.

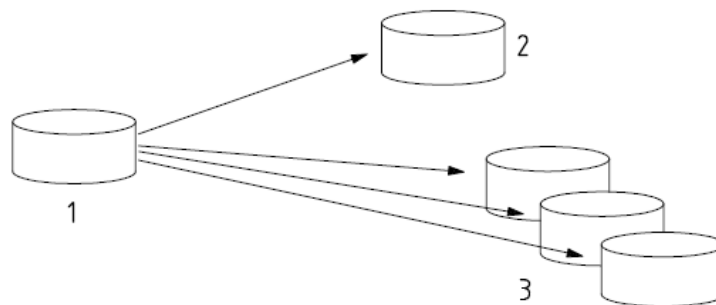

Key

- 1 ISO register of geodetic registers
- 2 ISO register of geodetic codes and parameters
- 3 ISO-approved external registers conforming to ISO 19111 and ISO 19135

Figure 22 — The ISO geodetic registry network

Rules for managing a register of geographical information items, including the submission of information, are found in ISO 19135.

There are additional rules for managing registers of geodetic codes and parameters. The minimum level of information that the register manager accepts from a submitting organization is complete data for a coordinate reference system or coordinate transformation that conforms to requirements as specified in Clause 7 of this Technical Specification. The register manager also accepts data for compound coordinate reference systems, single coordinate operations, and concatenated coordinate operations that conform to requirements of ISO 19111 and Clause 7 of this Technical Specification.

Higher-level records for coordinate reference system and coordinate transformation data are dependent on records for entities such as datums, coordinate systems, and coordinate operation parameters. The register manager assigns individual registration identifiers for records for entities

such as datums, coordinate systems, and coordinate operation parameters so that multiple higher-level records can point to them. When a record for an entity such as a datum, coordinate system, or coordinate operation parameter is modified, dependent records also are modified, according to rules in ISO 19135.

Data included in a register of geodetic codes and parameters conforms, at a minimum, to requirements of ISO 19111.

Additional rules for content of a register of geodetic codes and parameters are as follows:

- a) Information on scope of coordinate reference system and coordinate operation and their elements in accordance with ISO 19111 is mandatory for acceptance in the register. Some coordinate reference systems have a legal status in their valid area; this status is included in the scope.
- b) Information on valid area is mandatory for acceptance in the register.
- c) If the submitting organization uses geographic identifiers (as documented in ISO 19112) to describe valid area, it provides a citation to the source.
- d) The geographic area where use of the coordinate reference system is accepted is logically consistent with the geographic area where use of the datum is accepted and, if applicable, the geographic area where use of the map projection is accepted.
- e) Description of valid area for a coordinate operation is logically consistent with the valid areas for the source coordinate reference system and the target coordinate reference system.
- f) Information on datum type is mandatory for registration validation purposes.

Requirements for content of a subregister within the ISO geodetic registry network, as required by ISO 19111 and as specified in this clause, are documented in Tables B.1, B.2 and B.3. A mechanism for maintenance is discussed in ISO 19135.

This Technical Specification defines a set of data quality measures. These can be used when reporting data quality for the data quality subelements identified in ISO 19113. Multiple measures are defined for each data quality subelement, and the choice of which to use will depend on the type of data and its intended purpose. The data quality measures are structured so that they can be maintained in a register established in conformance with ISO 19135.

ISO 19113 describes data quality elements and their corresponding data quality subelements. It also specifies a set of descriptors for a data quality subelement. One of these descriptors is the data quality measure.

Figure 23 defines the components for data quality measures.

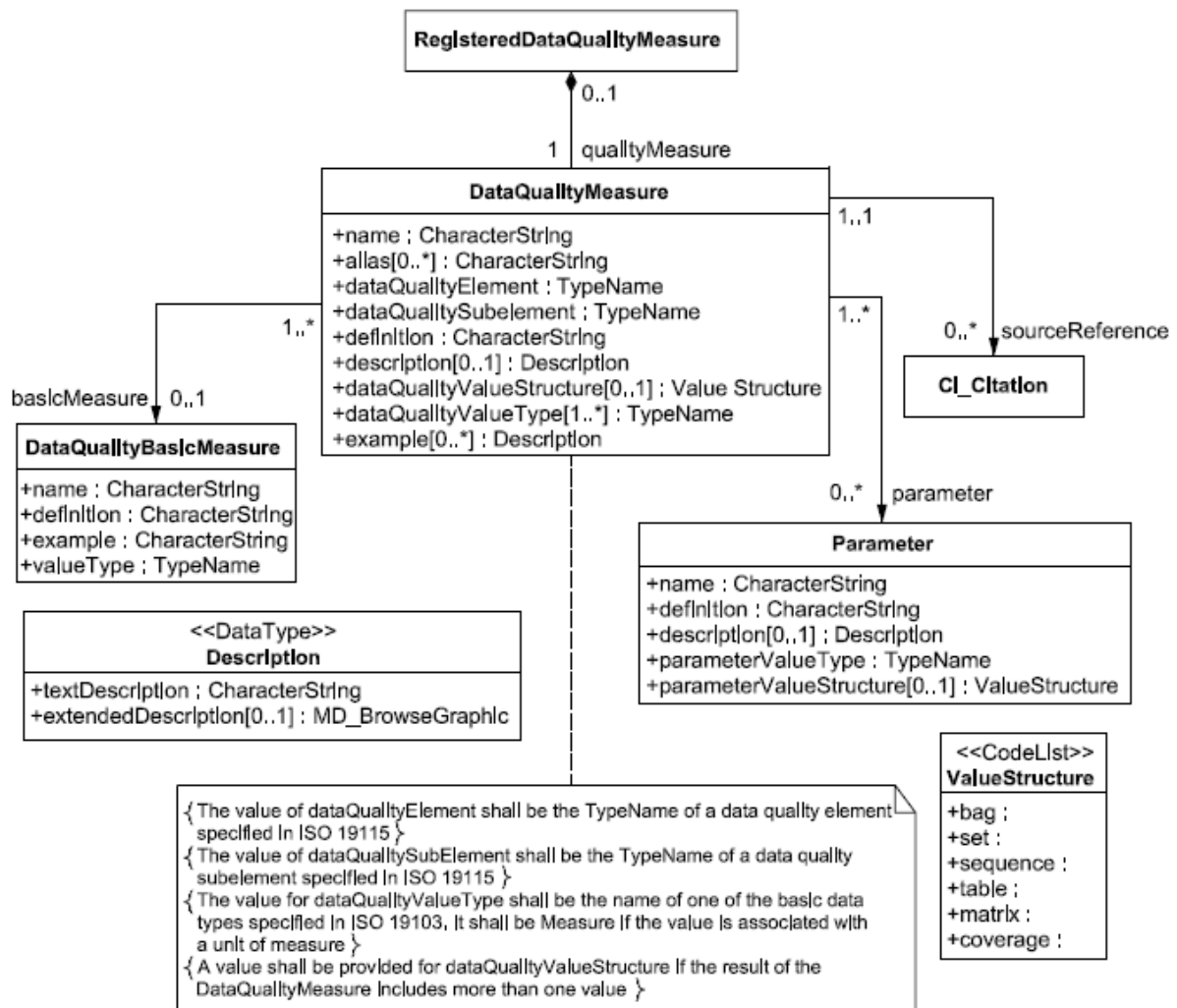

Figure 23 — Data quality measure

Annex D contains a list of commonly used data quality measures for completeness, logical consistency, positional accuracy, temporal accuracy, and thematic accuracy with all required components.

GEOGRAPHIC INFORMATION SERVICES STANDARDS

This set of standards builds on the architecture reference model of ISO 19101 to support the specification of geographic information services. ISO 19119 extends the architecture reference model to provide a framework for specifying individual geographic information services. ISO 19116 specifies an interface between position-providing devices and position-using devices. ISO 19117 provides a schema for specifying symbols and mapping them to an application schema. ISO 19125-1 describes a common architecture for providing access to information about features with simple geometry. ISO 19125-2 specifies a Structured Query Language implementation of ISO 19125-1. ISO 19128 specifies a set of interfaces for producing spatially referenced maps from geographic information available through the world wide web.

ISO 19132 provides a reference model and a framework for location base services. ISO 19133 provides a schema for describing the data and services needed to support tracking and navigation applications for mobile clients. ISO 19134 extends ISO 19133 to support mobile clients using two or more transportation modes to reach a destination.

The geographic services architecture specified in this International Standard has been developed to meet the following purposes:

- provide an abstract framework to allow coordinated development of specific services;
- enable interoperable data services through interface standardization;
- support development of a service catalogue through the definition of service metadata;
- allow separation of data instances and service instances;
- enable use of one provider's service on another provider's data;
- define an abstract framework which can be implemented in multiple ways.

This International Standard extends the architectural reference model defined in ISO 19101, in which an Extended Open Systems Environment (EOSE) model for geographic services is defined.

This International Standard defines the approach to defining services that is used in the ISO 19100 series of standards. Figure 24 defines the relationship between the various types of service specifications. `SV_ServiceSpecification` defines services without reference to the type of specification or to its implementation. A `SV_PlatformNeutralServiceSpecification` provides the abstract definition of a specific type of service but does not specify the implementation of the service. `SV_PlatformSpecificServiceSpecification` defines the implementation of a specific type of service. There may be multiple platform-specific specifications for a single platform-neutral specification. `SV_Service` is an implementation of a service. The requirements for these specifications are addressed in this International Standard, in particular in Clause 10.

The computational viewpoint described in Clause 7 provides the following:

- defines the concepts of services, interfaces and operations and the relations between these concepts;
- provides an approach to physical distribution of services using an n-tier architecture;
- defines a model for combining services in a dependent series to achieve larger tasks, e.g. service chaining;
- defines a service metadata model to support service discovery through a service catalogue.

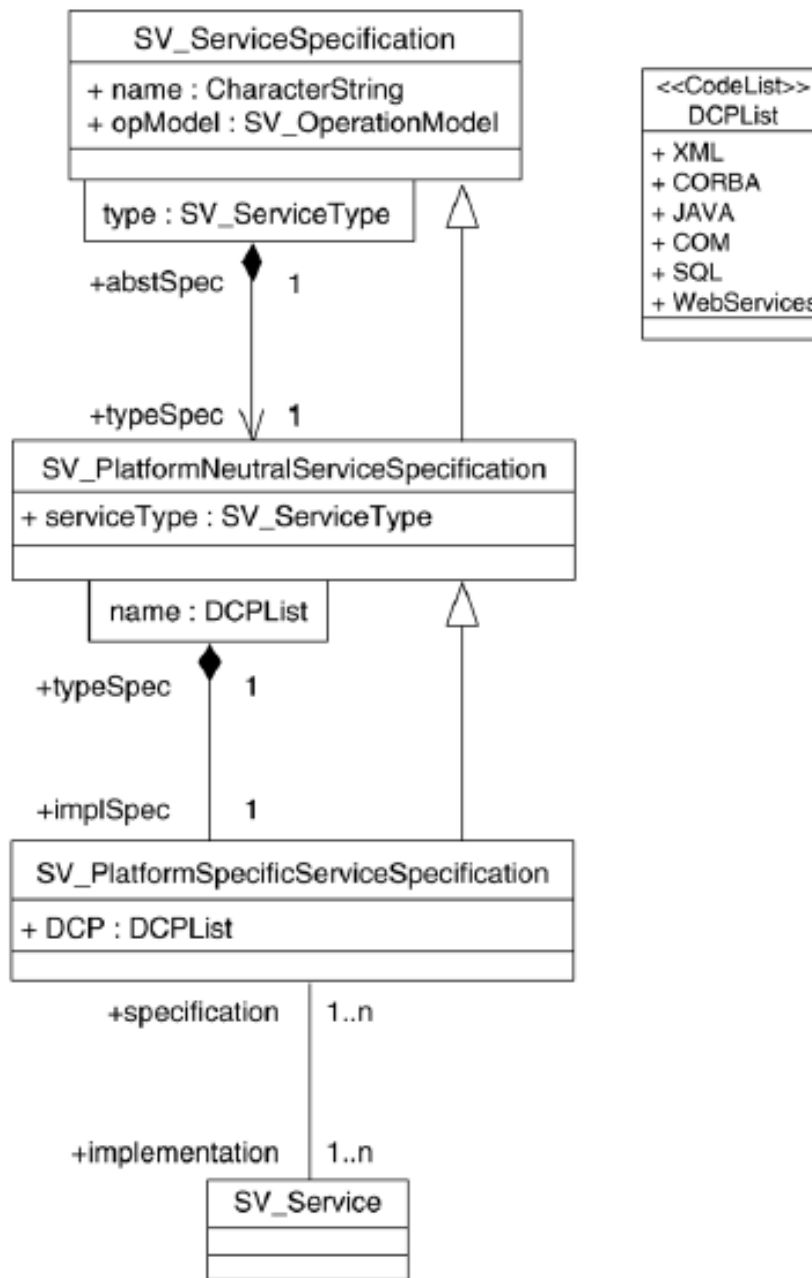

Figure 24 — Abstract and implementation service specifications

Consistent with ISO 19101, Subclause 8.3 defines six classes of information technology services that are used to categorize geographic services.

- Human interaction services are services for the management of user interfaces, graphics, multimedia, and for presentation of compound documents.
- Model/Information management services are services for the management of the development, manipulation, and storage of metadata, conceptual schemas, and datasets.
- Workflow/Task services are services for the support of specific tasks or work-related activities conducted by humans. These services support use of resources and development of products involving a sequence of activities or steps that may be conducted by different persons.
- Processing services are services that perform large-scale computations involving substantial amounts of data. Examples include services for providing the time of day, spelling checkers, and services that perform coordinate transformations, e.g. that accept a set of coordinates

expressed using one reference system and convert them to a set of coordinates in a different reference system. A processing service does not include capabilities for providing persistent storage of data or transfer of data over networks.

- Communication services are services for encoding and transfer of data across communications networks.
- System management services are services for the management of system components, applications and networks. These services also include management of user accounts and user access privileges.

Not every information-technology service needs to be changed or specialized to be useful for processing geographic information. A separation between geographic services and IT services is made in ISO 19101. This separation is emphasized because it is essential to identify and make use of general IT services whenever they exist.

This International Standard specifies the data structure and content of an interface that permits communication between position-providing device(s) and position-using device(s) so that the position-using device(s) can obtain and unambiguously interpret position information and determine whether the results meet the requirements of the use.

Positioning services employ a wide variety of technologies that provide position and related information to a similarly wide variety of applications, as depicted in Figure 25. Although these technologies differ in many respects, there are important items of information that are common among them and serve common needs of these application areas, such as the position data, time of observation and its accuracy. Also, there are items of information that apply only to specific technologies and are sometimes required in order to make correct use of the positioning results, such as signal strength, geometry factors, and raw measurements. Therefore, this International Standard includes both general data elements that are applicable to a wide variety of positioning services and technology specific elements that are relevant to particular technologies.

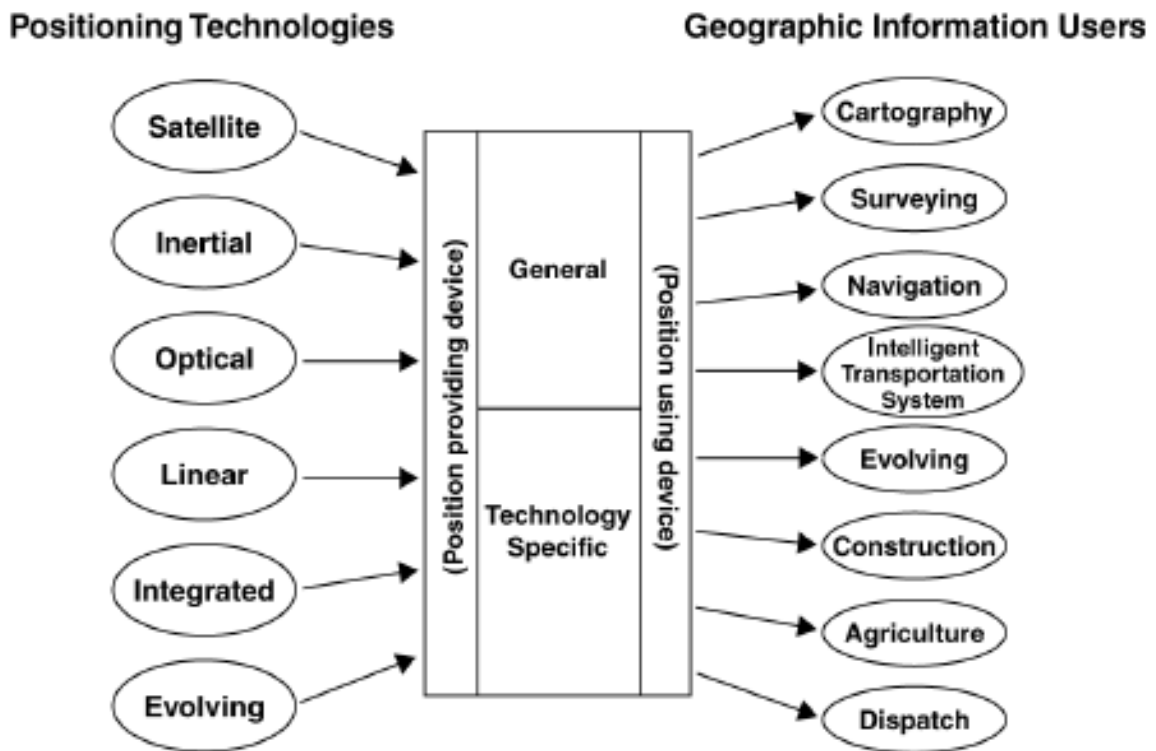

Figure 25 — Positioning services interface allows communication of position data for a wide variety of positioning technologies and users

Modern electronic positioning technology can measure the coordinates of a location on or near the Earth with great speed and accuracy, thereby allowing geographic information systems to be populated with any number of objects. However, the technologies for position determination have had neither a common structure for expression of position information, nor a common structure for expression of accuracy. The positioning-services interface specified in this International Standard provides data structures and operations that allow spatially oriented systems, such as GIS, to employ these technologies with greater efficiency by permitting interoperability among various implementations and various technologies.

Positioning services provide a means to obtain position information regarding a point or object. The data communication with a positioning service is structured in three classes:

- a) System information — held in the PS_System class, identifying the system and its capabilities;
- b) Session information — held in the PS_Session class, identifying a session of system operation;
- c) Mode information — held in the PS_ObservationMode class, identifying the configuration used in each mode of operation, the positioning observations (results) and any associated quality information.

The service is accessed through an interface that operates on these data classes, creating and destroying instances as necessary, and setting and getting information needed from the positioning service. This International Standard can be implemented as an interface between software modules within a system or as an interface between different systems. The relationships among these classes are depicted in Figure 26, and the details of these classes are discussed in Clause 7.

System information (PS_System) provides for identification and characterization of the positioning instrument(s) applied by the positioning service to make observations so that any necessary details can be obtained for operational purposes and for legacy metadata.

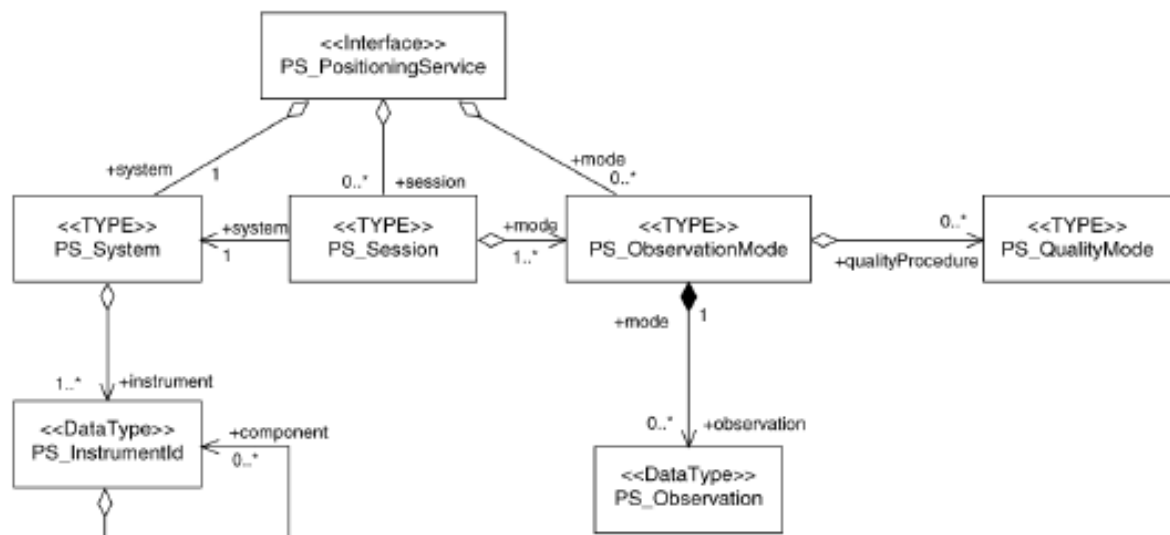

Figure 26 — UML depiction of the major data classes of positioning services

Observation mode information (PS_ObservationMode) encompasses all configuration and set-up parameters, including the spatial and temporal reference systems on which the observation results are cast. Associated with the mode may be data-quality configuration information, held in the PS_QualityElement class, that characterizes how quality results will be evaluated and expressed.

Positioning services can produce several types of observation: position, orientation (attitude), motion and rotation (angular motion). Because each type of observation is cast in its own type of reference system, a separate instance of the PS_ObservationMode class is created for each type of observation and the type is an attribute of the mode.

Observations are aggregated to each mode so that the information needed for interpretation is associated with each observation. A positioning service can create as many mode instances as needed for its various observation types and reference systems. Numerous observation results can belong to each mode.

Observations aggregated to modes of operation (PS_ObservationMode) can be further aggregated in sessions (PS_Session). The concept of observation sessions is widely employed when positioning observations are recorded for land survey or GIS applications. Sessions associate the observations with system information, attributes of the session, and all the modes of operation employed in making

a discrete group of positioning observations and any associated quality information. Positioning services that do not provide for the recording of observation results, such as certain navigation systems, may omit implementation of the PS_Session class.

Positioning-result information is segregated from configuration information in order to avoid excessive repetition of the configuration when the positioning service reports numerous observations. Similarly, quality-result information is segregated at the same level as positioning results, so that numerous quality reports of the same type, evaluated by the same procedure, can be reported without repetition of the element identification and evaluation procedure citation.

Quality results are associated directly with positioning observation results, and are held in the PS_ObservationQuality class, which is a subtype of the DQ_QualityMeasure class.

This International Standard defines a schema for describing the portrayal of geographic information in a form understandable by humans. It includes the methodology for describing symbols and mapping of the schema to an application schema. It does not include standardization of cartographic symbols, and their geometric and functional description.

This International Standard is an abstract document and is not intended for direct implementation. It gives general guidelines to application developers about the mechanism to be used to portray the feature instances of a dataset. The portrayal mechanism described makes it possible to have general rules valid for the whole dataset, and at the same time rules valid for a specific value of a feature attribute only. Different computer graphics standards use different attributes to visualize geometric primitives. For example, a line can be distinguished by thickness, width, colour, stippling, anti-aliasing, etc. This International Standard therefore includes a mechanism for declaring portrayal attributes as part of the portrayal specification.

In some cases whole feature classes have to be referenced and portrayed in a specific way, e.g. as symbols on nautical charts. Several symbol standards exist, and without a portrayal standard the application would have to set up a separate interface to each of these standards. With this International Standard all the supported symbol standards can be handled in a uniform way.

This International Standard defines a feature-centred rule-based portrayal mechanism. Instances of features are portrayed based on rules, which make use of geometry and attribute information. The relationship between the feature instances, attributes and the underlying spatial geometry is specified in an application schema according to ISO 19109.

Portrayal information is needed to portray a dataset containing geographic data. The portrayal information is handled as portrayal specifications applied according to specific portrayal rules (Clause 8). The portrayal mechanism makes it possible to portray the same dataset in different ways without altering the dataset itself.

The portrayal specifications and portrayal rules are not be part of the dataset. The portrayal rules are stored in a portrayal catalogue. The portrayal specifications are stored separately from the dataset and referenced from the portrayal rules. The portrayal rules are specified for the feature class or feature instances they will be applied on. The portrayal specifications may be stored externally and referenced using a universal reference standard such as a network based URL.

Portrayal information may be specified either by sending a portrayal catalogue and portrayal specifications with the dataset, or by referencing an existing portrayal catalogue and portrayal specifications from Metadata. In addition, the user may want to apply a user defined portrayal catalogue and portrayal specification.

The portrayal rules in the portrayal catalogue are tested on the attributes of the feature instances in the dataset. The portrayal rule is applied as a query statement that returns TRUE or FALSE. The portrayal specification associated with that particular portrayal rule is then applied. If no portrayal rule returns TRUE then the default portrayal specification is used.

A portrayal service is used to portray a feature instance or instances. The portrayal service applies operations using the parameters defined in a portrayal specification (8.4.2).

An optional priority attribute may be added to the portrayal rules. The attribute gives an integer value for deciding in which order portrayal rules are applied if more than one returns TRUE for one feature instance. A portrayal rule with a high priority number takes precedence over one with a lower number. If two portrayal rules returning TRUE have the same priority value, then the application decides which one takes precedence. If priority attributes are used, all the portrayal rules have a priority attribute.

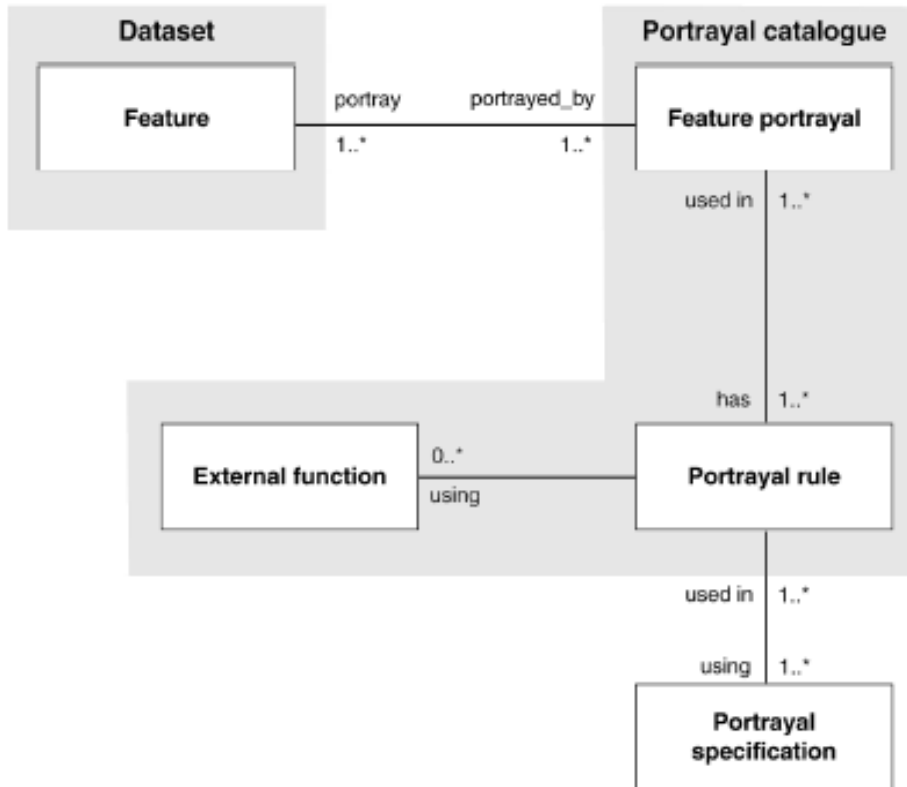

Figure 27 — Overview of portrayal

The portrayal catalogue consists of the feature portrayal, portrayal rule and external function, as shown in Figure 27. To produce different products, several portrayal catalogues may exist, portraying one or more datasets. The portrayal catalogue relates to one or more portrayal specifications, and one portrayal specification may be used in one or more portrayal catalogues. A portrayal rule consists of two parts: a query statement that can use one or more external functions, and one or more action statements.

The portrayal schema consists of three main parts:

- portrayal service, which defines the portrayal operations;
- portrayal catalogue package, which defines portrayal rules for the feature classes defined in an application schema;
- portrayal specification package, which defines the underlying parameters that are required by the portrayal service.

ISO 19125-1:2004 GEOGRAPHIC INFORMATION — SIMPLE FEATURE ACCESS —
PART 1: COMMON ARCHITECTURE

This part of ISO 19125 describes the common architecture for simple feature geometry. The simple feature geometry object model is Distributed Computing Platform neutral and uses UML notation. Part 2 of this International Standard describes an SQL implementation of the model.

This part of ISO 19125 implements a profile of the spatial schema described in ISO 19107:2003, *Geographic information — Spatial schema*. Annex A provides a detailed mapping of the schema in this part of ISO 19125 with the schema described in ISO 19107.

The base Geometry class has subclasses for Point, Curve, Surface and GeometryCollection. Each geometric object is associated with a Spatial Reference System, which describes the coordinate space in which the geometric object is defined. The extended Geometry model has specialized 0, 1 and 2-dimensional collection classes named MultiPoint, MultiLineString and MultiPolygon for modelling geometries corresponding to collections of Points, LineStrings and Polygons, respectively. MultiCurve and MultiSurface are introduced as abstract superclasses that generalize the collection interfaces to handle Curves and Surfaces.

The attributes, methods and assertions for each Geometry class are described in Figure 28.

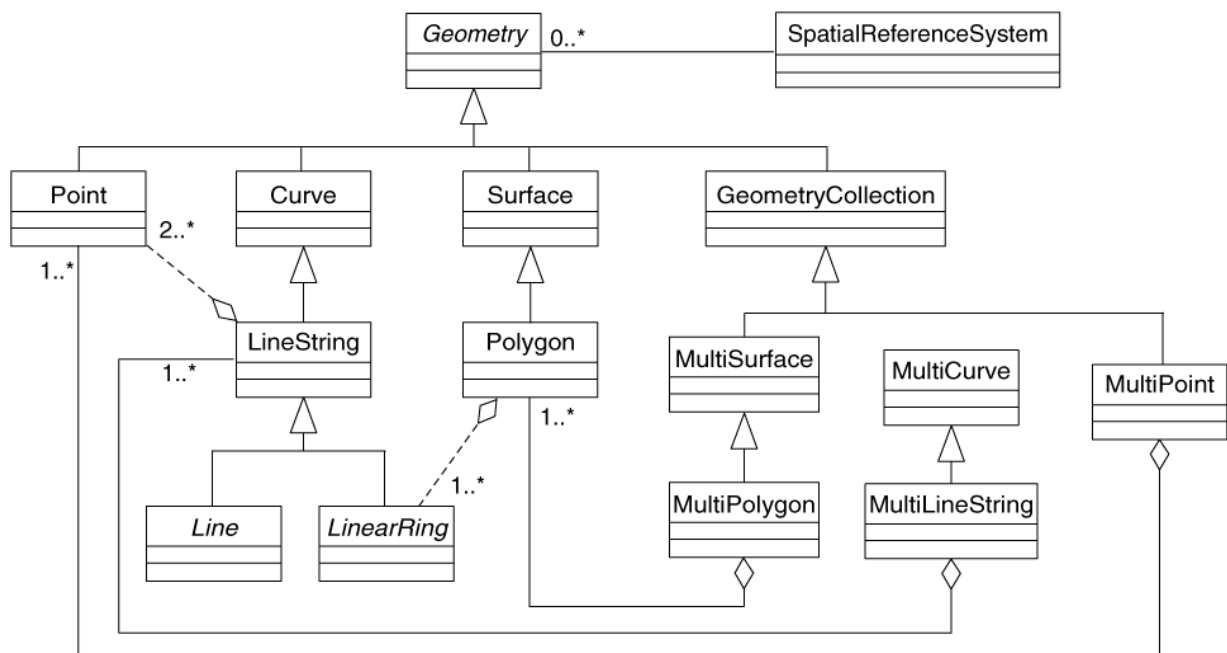

Figure 28 — Geometry class hierarchy

The relational operators are Boolean methods that are used to test for the existence of a specified topological spatial relationship between two geometric objects. The basic approach to comparing two geometric objects is to make pair-wise tests of the intersections between the interiors, boundaries and exteriors of the two geometric objects and to classify the relationship between the two geometric objects based on the entries in the resulting ‘intersection’ matrix.

Each Geometry Type has a Well-known Text Representation that can be used both to construct new instances of the type and to convert existing instances to textual form for alphanumeric display. The Well-known Text Representation of Spatial Reference Systems provides a standard textual representation for spatial reference system information.

The Well-known Binary Representation for Geometry (WKBGeometry) provides a portable representation of a geometric object as a contiguous stream of bytes. It permits geometric objects to be exchanged between an SQL/CLI client and an SQL-implementation in binary form.

ISO 19125:2004 GEOGRAPHIC INFORMATION — SIMPLE FEATURE ACCESS — PART 2: SQL OPTION

The purpose of this part of ISO 19125 is to define a standard Structured Query Language (SQL) schema that supports storage, retrieval, query and update of feature collections via the SQL Call-Level Interface (SQL/CLI) (ISO/IEC 9075-3:2003). A feature has both spatial and non-spatial attributes. Spatial attributes are geometry valued, and simple features are based on 2D geometry with linear interpolation between vertices. This part of ISO 19125 is dependent on the common architectural components defined in ISO 19125-1.

This part of ISO 19125 defines a schema for the management of feature table, Geometry, and Spatial Reference System information in an SQL-implementation based on predefined data types. This part of ISO 19125 does not define SQL functions for access, maintenance, or indexing of Geometry in an SQL-implementation based on predefined data types.

Feature collections are stored as tables with geometry valued columns in a SQL-implementation; each feature is a row in the table. The non-spatial attributes of features are mapped onto columns whose types are drawn from the set of standard SQL data types. The spatial attributes of features are mapped onto columns whose SQL data types are based on the underlying concept of additional geometric data types for SQL. A table whose rows represent these features is referred to as a feature table. Such a table contains one or more geometry valued columns. Feature-table schemas are described for two SQL-implementations: implementations based on predefined data types and SQL with Geometry Types.

In an implementation based on predefined data types, a geometry-valued column is implemented as a Foreign Key reference into a geometry table. A geometry value is stored using one or more rows in the geometry table. The geometry table may be implemented using either standard SQL numeric types or SQL binary types; schemas for both are described.

The term SQL with Geometry Types is used to refer to a SQL-implementation that has been extended with a set of Geometry Types. In this environment, a geometry-valued column is implemented as a column whose SQL type is drawn from this set of Geometry Types. The mechanism for extending the type system of an SQL-implementation is through the definition of user defined User Defined Types. Commercial SQL-implementations with user defined type support have been available since mid-1997.

Figure 29 illustrates the schema to support feature tables, Geometry, and Spatial Reference Information in an SQL-implementation based on predefined data types.

- a) The GEOMETRY_COLUMNS table describes the available feature tables and their Geometry properties.
- b) The SPATIAL_REF_SYS table describes the coordinate system and transformations for Geometry.
- c) The feature table stores a collection of features. A feature table's columns represent feature attributes, while rows represent individual features. The Geometry of a feature is one of its feature attributes; while logically a geometric data type, a Geometry Column is implemented as a foreign key to a geometry table.
- d) The geometry table stores geometric objects, and may be implemented using either standard SQL numeric types or SQL binary types.

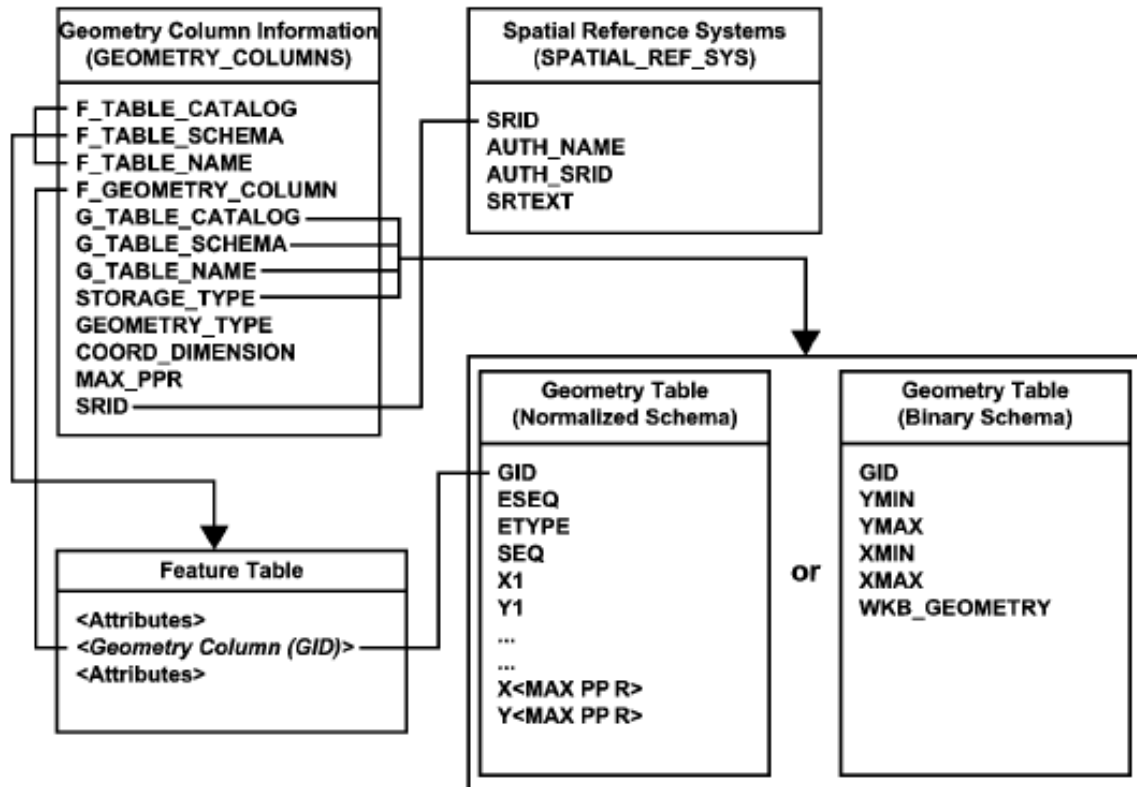

Figure 29 — Schema for feature tables using predefined data types

This International Standard specifies the behaviour of a Web Map Service (WMS) that produces spatially referenced maps dynamically from geographic information. It specifies operations to retrieve a description of the maps offered by a server to retrieve a map, and to query a server about features displayed on a map. This International Standard is applicable to pictorial renderings of maps in a graphical format; it is not applicable to retrieval of actual feature data or coverage data values.

This International Standard defines a “map” to be a portrayal of geographic information as a digital image file suitable for display on a computer screen. A map is not the data itself. WMS-produced maps are generally rendered in a pictorial format such as PNG, GIF or JPEG, or occasionally as vector-based graphical elements in Scalable Vector Graphics (SVG) or Web Computer Graphics Metafile (WebCGM) formats.

This International Standard defines three operations: one returns service-level metadata; another returns a map whose geographic and dimensional parameters are well-defined; and an optional third operation returns information about particular features shown on a map. Web Map Service operations can be invoked using a standard web browser by submitting requests in the form of Uniform Resource Locators (URLs). The content of such URLs depends on which operation is requested. In particular, when requesting a map the URL indicates what information is to be shown on the map, what portion of the Earth is to be mapped, the desired coordinate reference system, and the output image width and height. When two or more maps are produced with the same geographic parameters and output size, the results can be accurately overlaid to produce a composite map. The use of image formats that support transparent backgrounds (e.g. GIF or PNG) allows underlying maps to be visible. Furthermore, individual maps can be requested from different servers. The Web Map Service thus enables the creation of a network of distributed map servers from which clients can build customized maps. Illustrative examples of map request URLs and their resulting maps are shown in Annex G.

This International Standard applies to a Web Map Service instance that publishes its ability to produce maps rather than its ability to access specific data holdings. A basic WMS classifies its geographic information holdings into “Layers” and offers a finite number of predefined “Styles” in which to display those layers. This International Standard supports only named Layers and Styles, and does not include a mechanism for user-defined symbolization of feature data.

NOTE The Open Geospatial Consortium (OGC) Styled Layer Descriptor (SLD) specification defines a mechanism for user-defined symbolization of feature data instead of named Layers and Styles. In brief, an SLD-enabled WMS retrieves feature data from a Web Feature Service and applies explicit styling information provided by the user in order to render a map.

The three operations defined for a WMS are `GetCapabilities`, `GetMap`, and `GetFeatureInfo`. `GetFeatureInfo` is optional.

The purpose of the mandatory `GetCapabilities` operation is to obtain service metadata, which is a machine-readable (and human-readable) description of the server’s information content and acceptable request parameter values. When invoked on a WMS, the response to a `GetCapabilities` request is an XML document containing service metadata formatted according to the XML Schema in E.1. The schema specifies the mandatory and optional content of the service metadata and how the content is formatted.

The `GetMap` operation returns a map. Upon receiving a `GetMap` request, a WMS either satisfies the request or issue a service exception. The response to a valid `GetMap` request is a map of the spatially referenced information layer requested, in the desired style, and having the specified coordinate reference system, bounding box, size, format and transparency.

`GetFeatureInfo` is an optional operation. It is only supported for those Layers for which the attribute `queryable="1"` (true) has been defined or inherited. The `GetFeatureInfo` operation is designed to provide clients of a WMS with more information about features in the pictures of maps that were returned by previous Map requests. The canonical use case for `GetFeatureInfo` is that a user sees the

response of a Map request and chooses a point (I,J) on that map for which to obtain more information. The basic operation provides the ability for a client to specify which pixel is being asked about, which layer(s) should be investigated, and what format the information should be returned in.

ISO 19132:2007 GEOGRAPHIC INFORMATION — LOCATION BASED SERVICES — REFERENCE MODEL

This International Standard defines a reference model and a conceptual framework for location-based services (LBS), and describes the basic principles by which LBS applications may interoperate. This framework references or contains an ontology, a taxonomy, a set of design patterns and a core set of LBS service abstract specifications in UML. This International Standard further specifies the framework's relationship to other frameworks, applications and services for geographic information and to client applications.

This International Standard addresses for an LBS system the first three basic viewpoints as defined in the Reference Model for Open Distributed Processing (RM-ODP; ISO/IEC 10746).

This International Standard

- defines the conceptual framework for and the type of applications included within LBS,
- establishes general principles for LBS for both mobile and fixed clients,
- specifies the interface for data access while roaming,
- defines the architectural relationship with other ISO geographic information standards,
- identifies areas in which further standards for LBS are required.

A reference model is a conceptual framework consisting of a set of system decisions, both architectural and policy, which construct the logical environment for a set of applications and processes within a specific domain. A framework contains or references a taxonomy of terms and an ontology that defines the target domain. A framework may contain or reference other frameworks for related application sets or design paradigms. An LBS framework may relate to a framework of geographic information services, since much of its activity is associated to manipulation of location representations and the use of location as a key to other services. Models for frameworks exist at a variety of levels of abstractions, each of which is a generalization of the more detailed model, and a specialization of the more general ones. At the highest level, the only entities are the frameworks representing their respective reference models. This is illustrated in Figure 30.

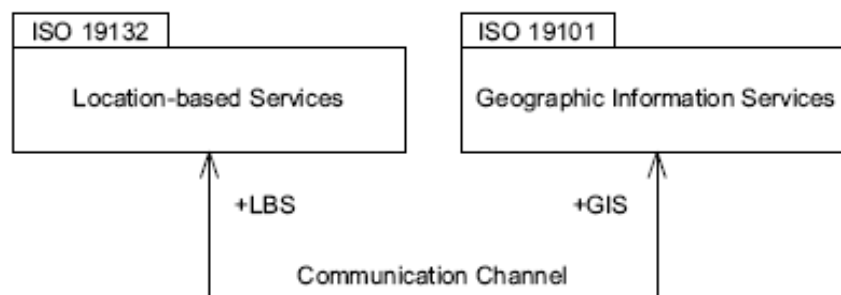

Figure 30 — Relation between LBS and GIS

What this says, in its simplest and most direct terms, is that the two frameworks are coupled, and depending on form more than on functionality, each will invoke services (functions) supplied by the other. This International Standard deals with the communication across the channel depicted in this figure. It does so by creating a reference model for the location-based services framework and linking it to the reference model defined in ISO 19101 and ISO/TS 19101-2.

A distinction between an LBS service¹⁾ and a GIS service²⁾ is that LBS will normally have a larger granularity and significant non-spatial information component, and therefore must be able to interact with both geographic data frameworks and with general information frameworks containing non-spatial data. Such data may be spatially linked in manners not traditionally used in geographic systems, such as by postal address, or telephone number. Another distinction is that LBS services have to deal with the delivery mechanism at a finer level than GIS frameworks. LBS clients are likely

to include mobile devices on a multitude of network types, and with a wide variety of capabilities. Thus, an LBS framework must support the same services through a variety of different interface protocols, each tailored for a class of client needs and capabilities. While the details of each client device's interface protocols are beyond the scope of this International Standard, it does address the common semantics of all of the LBS client classes by defining a set of common patterns that provide extensible templates for applications within this domain.

The enterprise specification provides a description of the requirements and objectives that the environment imposes on the system (ISO/IEC 10746-1). The enterprise concepts of enterprise objects fulfilling roles of performative actions are used to describe the multiparty service orchestration inherent in the system concept described above. The roles that the stakeholders in location-based services can play with respect to a service are user, broker or provider. For the application and supporting service broker system, this specification results in the identification of consumer objects (users) and of objects managing these users through applications (service brokers and application provider). For the supporting network infrastructure, a service provider object manages the binding object.

In the information specification, the semantics and requirements for the processing of the service information are specified. This is done using the UML schema definitions in the framework Clauses of this International Standard (Clauses 8 and 9). Since the roles of the participants of the system vary in their view, distinct schemata may be required in some situations for user–broker and broker–service interactions.

The computational specification is a description of the system's functionality consistent with the enterprise and information specifications. This is done in the UML operation definitions in the framework Clauses of this International Standard (Clauses 8 and 9). The correspondences between objects in the information specification and objects in the computational specification are specified in each case so that consistency between the specifications can be assured.

The model supporting this International Standard consists of several packages describing the participants in the LBS community and the services and data employed by them. The package structure for this International Standard is detailed in Figure 31.

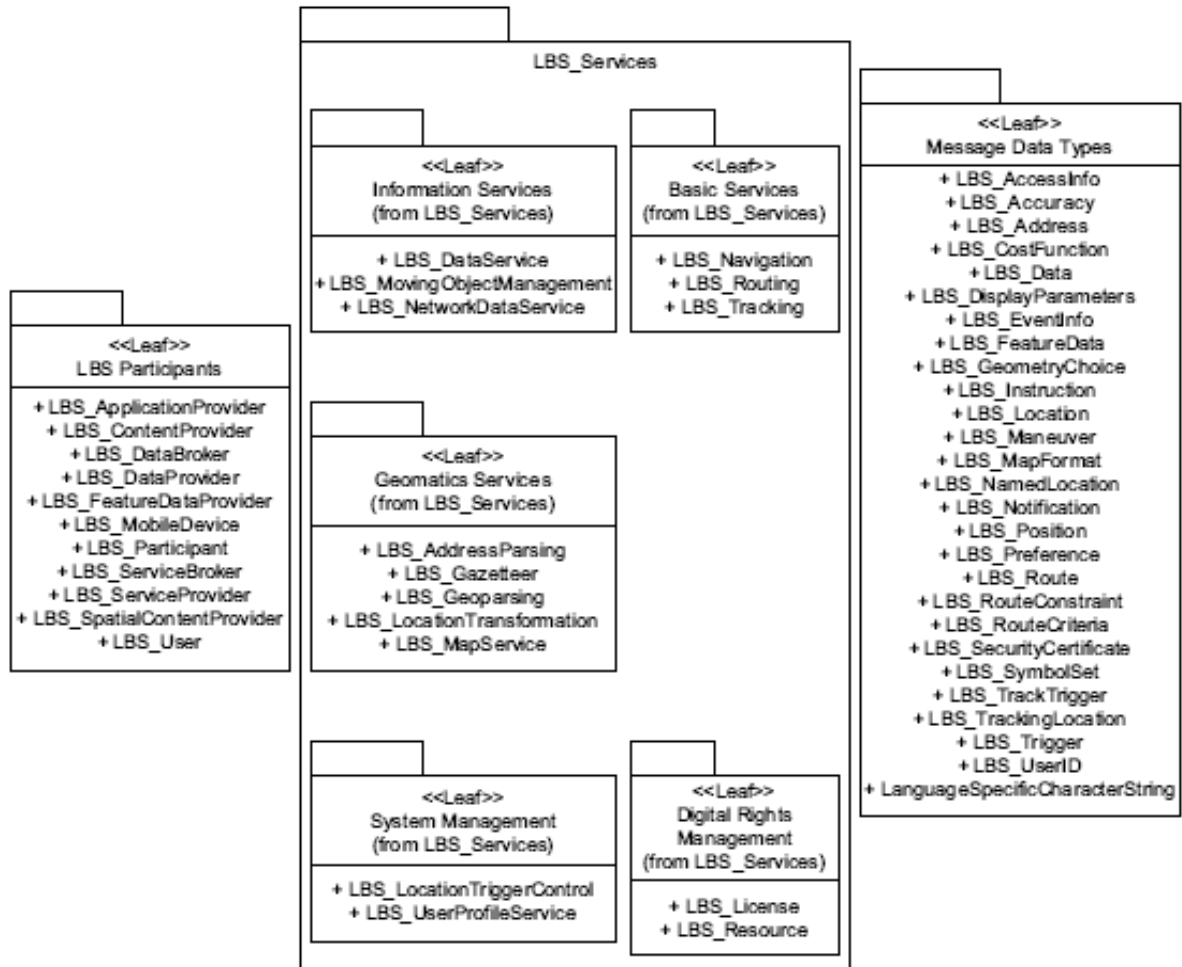

Figure 31 — Overview of UML package structure

ISO 19133:2005 GEOGRAPHIC INFORMATION — LOCATION BASED SERVICES — TRACKING AND NAVIGATION

This International Standard is a description of the data and services needed to support tracking and navigation applications for mobile clients. The web services views of this International Standard are given in Annex C. This International Standard describes the data types, and operations associated with those types, for the implementation of tracking and navigation services. This International Standard is designed to specify web services that can be made available to wireless devices through web-resident proxy applications, but is not restricted to that environment.

Clauses 6 and 7 of this International Standard use the Unified Modeling Language (UML) to present conceptual schemas for describing the information and services for tracking and navigation. Clause 8 further describes a general schema for addresses to be used as location equivalents in three types of services. Clause 9 describes network data appropriate for these services. This International Standard concerns only externally visible interfaces and places no restriction on the underlying implementations other than what is needed to satisfy the interface specifications in the actual situation, such as

- interfaces to software services using techniques such as COM or CORBA;
- interfaces to databases using techniques such as SQL;
- data interchange using encoding as defined in ISO 19118.

Few applications will require the full range of capabilities described by this conceptual schema.

The basic Engineering Viewpoint assumption is that the services described in this International Standard will be made available on the web to be accessed by mobile devices, whose web connection may be transient, in a manner similar to permanently on-web clients. The exception is that the mobile client can either update or request an update of its own geographic location at one or more times during the process of the service interaction. There are no specific requirements on the network platform, and the interface and data definitions in this International Standard are platform neutral.

A web-resident, and persistent, proxy application for the mobile client is required to make this possible. This proxy acts as a device transformer for messages and embedded data flowing between the service and the mobile client. The interface between the mobile client and the on-web proxy is not within the scope of this International Standard and is covered by International Standards written by and within ISO/TC 204. This conceptual architecture is shown in Figure 32. In that diagram, thin and medium client nodes appear at the top of the diagram. The other nodes on the network are persistent, on-web services available to mobile clients through their "Proxy Application and Device Transformer". Services specifically defined in this International Standard are marked as such. Other services in Figure 32 are examples, but may represent functionality required for the marked service. For example, "Gazetteer Service" should be compliant with ISO 19112.

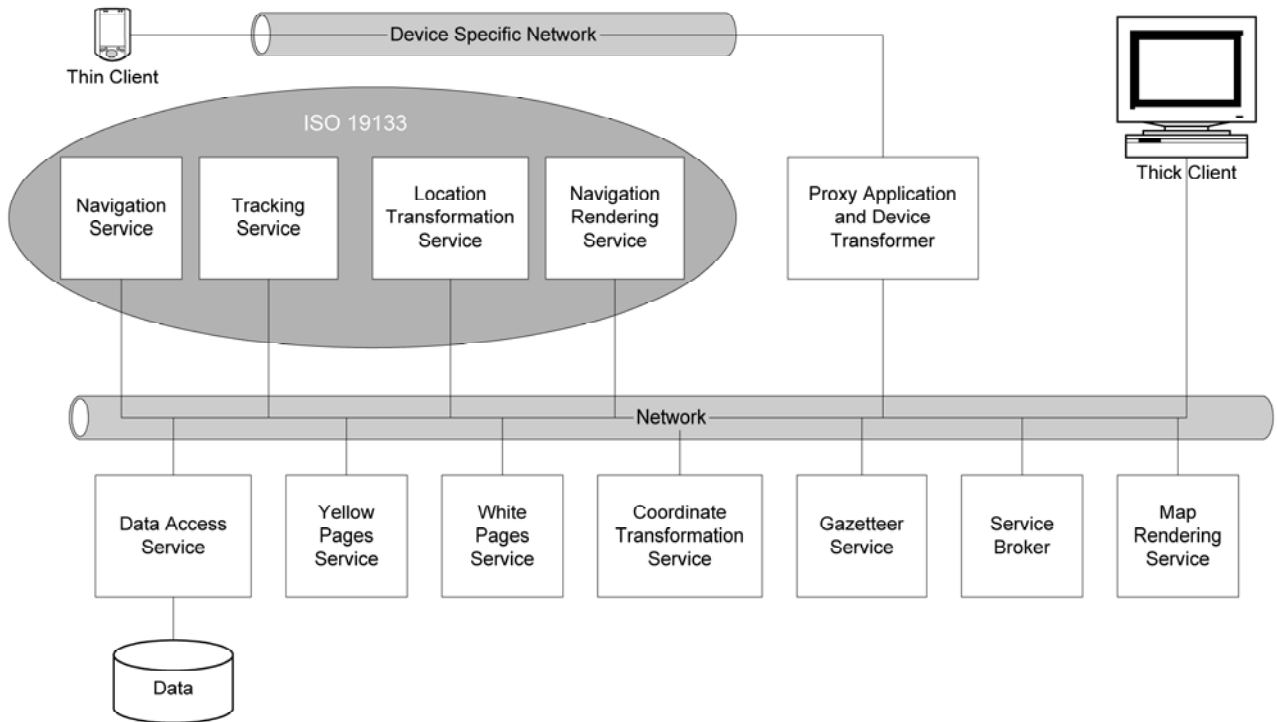

Figure 32 — Conceptual architecture equating mobile and non-mobile services

The second assumption is that the state of the mobile client will be maintained by the client application or by its on-web proxy application. This means that all requests for services will be totally encapsulated in a request–response pair. The operations will all be prototypically represented as

`<serviceType> :: <svrOperation>(<serviceRequest>) : <serviceResponse>`

Thus, we have a service model based on sets of three basic types:

- a service type (listing of service operations);
- a set of service request data types associated with some number of operations;
- a set of service response data types associated with some number of operations.

The data types will have a core set of required components and another set of optional components that can affect the outcome and semantics of the operations. For example, the simplest form of navigation requires simply a “from target position” and a “to target position”, but can be modified by sending an optional description of a different cost function.

ISO 19134:2007 GEOGRAPHIC INFORMATION — LOCATION BASED SERVICES —
MULTIMODAL ROUTING AND NAVIGATION

This International Standard provides a conceptual schema for describing the data and services needed to support routing and navigation application for mobile clients who intend to reach a target position using two or more modes of transportation. This International Standard provides a description of a service type to support routing and navigation for a mode that operates either on a fixed route or with a fixed schedule, a description of data type for transfers, and a description of data type for schedule information and route information of a mode with a fixed route and/or schedule.

Based upon ISO 19133, this International Standard specifies additional classes as well as extensions to existing classes to be used for multimodal routing and navigation. As in ISO 19133, this International Standard assumes that all requests for services will be encapsulated in a request/response pair between the mobile client and the client application or its on-web proxy application. Therefore, this International Standard describes service operation types and a set of request/response data types associated with some operations which are necessary for multimodal routing and navigation.

The model for multimodal LBS for routing and navigation consists of the ISO 19133 package and five leaf packages: Multimodal Network, Multimodal Routing, Multimodal Constraint and Advisory, Multimodal Cost Function, and Multimodal Navigation Service. In addition to the appropriate types and classes of ISO 19133, the five leaf packages contain types and classes which are necessary to create a multimodal LBS routing and navigation service. Figure 33 shows the dependencies among those leaf packages, including the ISO 19133 package.

Multimodal location-based service utilizes networks of public transportation modes that operate on fixed and/or flexible schedule routes, using either road networks or guided networks. Preferable travel modes are decided and travel costs are calculated based on user preference and/or on cost functions.

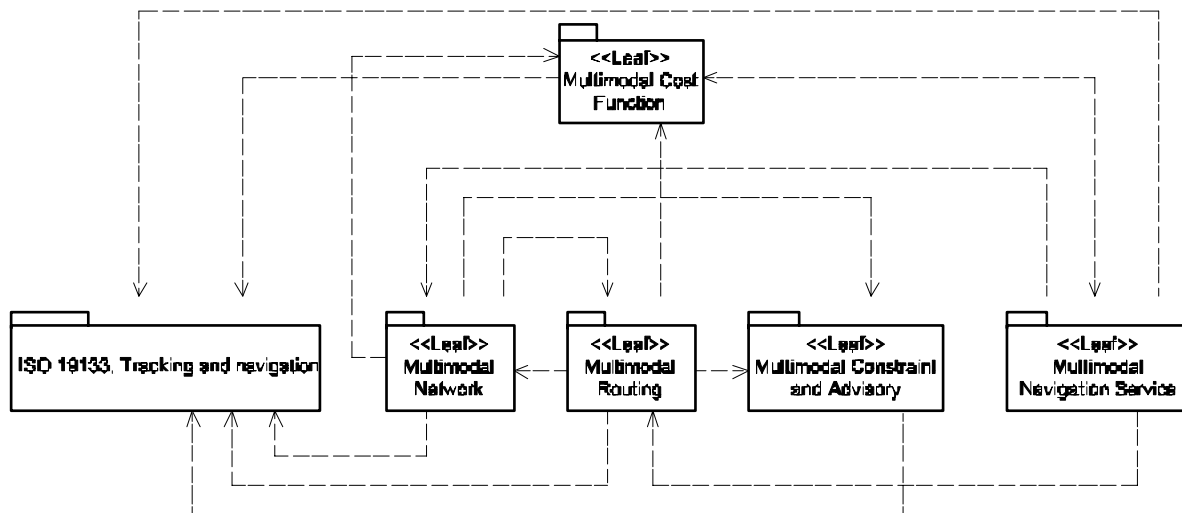

Figure 33 — Package dependencies

GEOGRAPHIC INFORMATION ENCODING STANDARDS

As indicated by the architecture reference model of ISO 19101, encoding standards are needed to support the interchange of geographic information between systems. ISO 19118 provides a model for rule based encoding of data that conforms to an application schema. ISO 6709 specifies the representation of coordinates used to describe point locations. ISO 19136 specifies ISO 19118 compliant XML encodings of a number of the conceptual classes defined in the ISO 19100 series of International Standards. ISO/TS 19139 defines Geographic MetaData XML (gmd) encoding, an XML schema implementation derived from ISO 19115 and compliant with ISO 19118.

This International Standard specifies:

- requirements for creating encoding rules based on UML schemas,
- requirements for creating encoding services,
- an informative XML based encoding rule for neutral interchange of geographic data.

Encoding rules allow geographic information defined in an application schema to be coded into a system independent data structure suitable for transport or storage. The encoding rule specifies the types of data to be coded and the syntax, structure and coding schemes used in the resulting data structure. The resulting data structure may be stored on digital media or transferred using transfer protocols. It is intended to be read and interpreted by computers, but may be in a form that is human readable.

The standard is divided into three logical sections. The requirements for creating encoding rules based on UML schemas are described in Clauses 6, 7 and 8. The requirements for creating an encoding service are described in Clause 9, and the informative XML based encoding rule is described in Annex A.

The XML based encoding rule is intended to be used for neutral data interchange. It relies on the Extensible Markup Language (XML) and the ISO/IEC 10646 character set standards. Introductions to XML and ISO/IEC 10646 are given in Annexes C and D respectively. Annex E contains examples of the application of this International Standard.

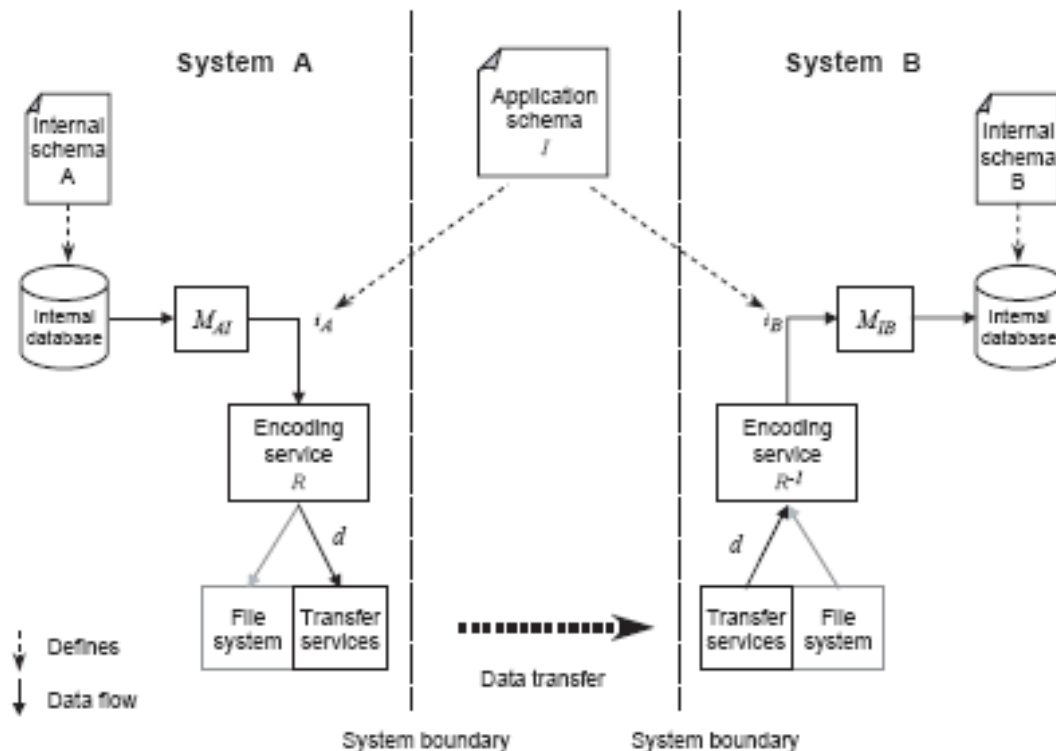

Figure 34 — Overview of data interchange between two systems

An overview of a data interchange is shown in Figure 34. System A wants to send a dataset to system B. To ensure a successful interchange A and B must decide on three things, i.e. a common application schema I, which encoding rule to apply R and what kind of transfer protocol to use. The application schema is the basis of a successful data transfer and defines the possible content and structure of the transferred data, whereas the encoding rule defines the conversion rules for how to code the data into a system independent data structure.

An encoding rule is an identifiable collection of conversion rules that defines the encoding for a particular data structure. The encoding rule specifies the data types to be converted, as well as the syntax, structure and coding schemes used in the resulting data structure. An encoding rule is applied to application schema specific data structures to produce system-independent data structures suitable for transport or storage. In order to define an encoding rule three important aspects must be specified, i.e. the input data structure, the output data structure and the conversion rules between the elements of the input and the output data structures. Both the input and output data structures are written using a conceptual schema language and the concepts in the languages are used to define the encoding rule.

A conversion rule specifies how a data instance in the input data structure is converted to zero, one, or more instances in the output data structure. The conversion rules are defined and based on the concepts of the conceptual schema language C and on the concepts of the output data structure schema D.

An encoding service is a software component that has implemented the encoding rule and provides an interface to encoding and decoding functionality. It is an integrated part of data interchange. The encoding service is able to read the input data structure and convert the instances to an output data structure and vice versa. It is also able to read the application schema declarations and write the corresponding output data structure schema. The input data structure is defined by an application schema. The application schema is defined using concepts of the conceptual schema language. The output data structure is also described with a schema, called the data structure schema, which defines the possible content, structure and coding schemes of the output data structure. The data structure schema is described with a schema language. The encoding rule specifies conversion rules at two levels, the first is at the schema level and the second is at the instance level. At the schema level, the conversion rules define a mapping for each of the concepts defined in the application schema to corresponding concepts in the data structure schema. At the instance level the conversion rules define a mapping for each of the instances in the input data structure to corresponding instances in the output data structure. The instance conversion rules are normally deduced from the schema conversion rules.

A transfer service is a software component that has implemented one or more transfer protocols, which allows data transfer between distributed information systems over off-line or on-line communication media. To successfully transfer data between two systems the sender and receiver need to agree on the transfer protocol to be used. This International Standard does not prescribe any preferred transfer protocols.

ISO 6709:2008 STANDARD REPRESENTATION OF GEOGRAPHIC LOCATION BY COORDINATES

This International Standard is applicable to the interchange of coordinates describing geographic point location. It specifies the representation of coordinates including latitude and longitude to be used in data interchange. It additionally specifies representation of horizontal point location using coordinate types other than latitude and longitude. It also specifies the representation of height and depth that may be associated with horizontal coordinates. Representation includes units of measure and coordinate order.

This International Standard is not applicable to the representation of information held within computer memories during processing and in their use in registers of geodetic codes and parameters.

Efficient interchange of geographic point location data requires formats which are universally interpretable and which allow identification of points on, above and below the earth's surface. Users in various disciplines may have different requirements. This is exemplified by the use of degrees and decimal degrees as well as the traditional degrees, minutes and seconds for recording latitude and longitude. Users may also require various levels of precision and may use latitude and longitude without height.

The first edition of this International Standard (ISO 6709:1983) provided for the representation of latitude and longitude for geographic point locations. This second edition extends use of the representation to applications requiring latitude or longitude values to be quoted separately, for example when quoting a difference in two meridian values. It also extends the representation of latitude and longitude to allow the values for each to be held in separate numeric fields.

This edition of the International Standard additionally provides for representation of horizontal point location by coordinates other than latitude and longitude and makes provisions for a variable-length format which has the flexibility to cover these various requirements. It also includes provisions for heights and depths.

This International Standard is primarily intended for data interchange between computer systems. An informative annex summarizing the different requirements at the human interface has been added.

This International Standard supports point location representation through the eXtensible Markup Language (XML) and, recognizing the need for compatibility with the previous version of this International Standard, ISO 6709:1983, allows for the use of a single alpha-numeric string to describe point locations.

For computer data interchange of latitude and longitude, this International Standard generally suggests that decimal degrees be used. It allows the use of sexagesimal notations – degrees, minutes and decimal minutes or degrees, minutes, seconds and decimal seconds.

This International Standard does not require special internal procedures, file organization techniques, storage medium, languages, etc., to be used in its implementation.

The first edition of this International Standard used the term altitude to describe vertical position. This International Standard uses the more general term height and also allows for vertical location to be described through depth.

A coordinate is one of a sequence of numbers describing the position of a point. A coordinate tuple is composed of a sequence of coordinates describing one position.

EXAMPLE A coordinate tuple consisting of latitude, longitude and height represents a three-dimensional geographic position.

A coordinate tuple represents location unambiguously only if the coordinate reference system (CRS) to which it is referenced is identified. Without this identification, uncertainty in position may result for

the location may be as much as several hundred metres distant – see Annex B. ISO 19111 defines the elements required to describe a coordinate reference system.

A coordinate set is a collection of coordinate tuples. ISO 19111 requires that all coordinate tuples within a coordinate set be referenced to the same coordinate reference system. If only one point is being described the association between coordinate tuple and coordinate reference system may be direct. For a coordinate set, one CRS identification or definition is associated with the coordinate set and all coordinate tuples in that coordinate inherit that association. The conceptual relationship between coordinate tuple, coordinate set and coordinate reference system is illustrated in Figure 35 and is formally described in UML in Annex C.

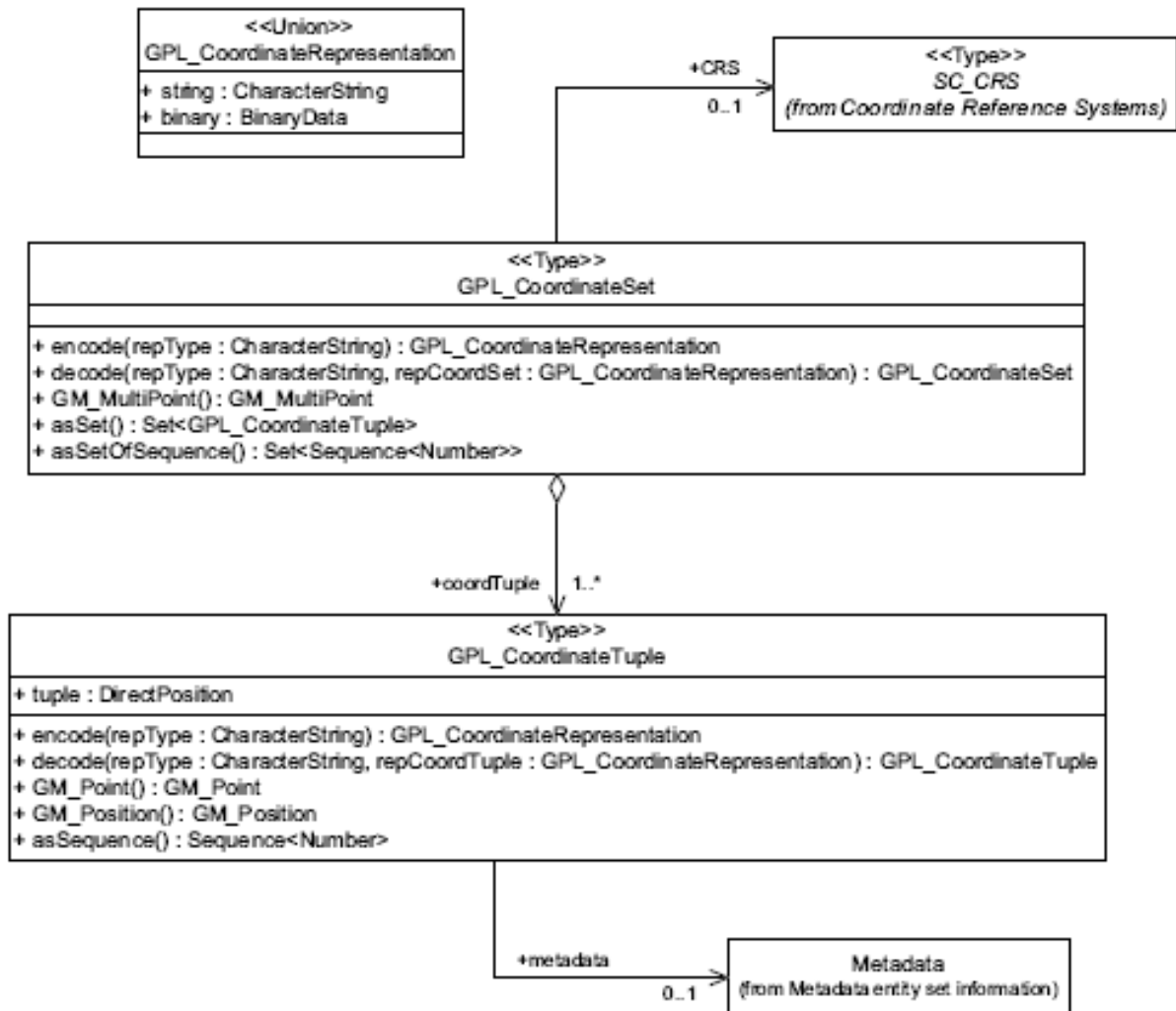

Figure 35 — UML Model for coordinate representation

ISO 19136:2007 GEOGRAPHIC INFORMATION — GEOGRAPHY MARKUP LANGUAGE (GML)

The Geography Markup Language (GML) is an XML encoding in compliance with ISO 19118 for the transport and storage of geographic information modelled according to the conceptual modelling framework used in the ISO 19100 series of International Standards and including both the spatial and non-spatial properties of geographic features.

This International Standard defines the XML Schema syntax, mechanisms, and conventions that:

- Provide an open, vendor-neutral framework for the description of geospatial application schemas for the transport and storage of geographic information in XML;
- Allow profiles that support proper subsets of GML framework descriptive capabilities;
- Support the description of geospatial application schemas for specialized domains and information communities;
- Enable the creation and maintenance of linked geographic application schemas and datasets;
- Support the storage and transport of application schemas and data sets;
- Increase the ability of organizations to share geographic application schemas and the information they describe.

Implementers may decide to store geographic application schemas and information in GML, or they may decide to convert from some other storage format on demand and use GML only for schema and data transport.

GML specifies XML encodings of a number of the conceptual classes defined in the ISO 19100 series of International Standards and the OpenGIS Abstract Specification in conformance with these standards and specifications.

The relevant conceptual models include those defined in:

- ISO/TS 19103 – Conceptual schema language (units of measure, basic types),
- ISO 19107 – Spatial schema (spatial geometry and topology),
- ISO 19108 – Temporal schema (temporal geometry and topology, temporal reference systems),
- ISO 19109 – Rules for application schemas (features),
- ISO 19111 – Spatial referencing by coordinates (coordinate reference systems),
- ISO 19123 – Schema for coverage geometry and functions (coverages, grids)

In many cases, the mapping from the conceptual classes to XML is straightforward, while in some cases the mapping is more complex. For both cases, the mapping is documented in detail in Annex D. In addition, GML provides XML encodings for additional concepts not yet modelled in the ISO 19100 series of International Standards or the OpenGIS Abstract Specification. Examples include moving objects, simple observations or value objects. Additional conceptual classes corresponding to these extensions are also specified in Annex D.

The GML schema comprises the components (XML elements, attributes, simple types, complex types, attribute groups, groups, etc.) that are described in this International Standard.

Designers of GML application schemas may extend or restrict the types defined in the GML schema to define appropriate types for an application domain. Non-abstract elements, attributes and types from the GML schema may be used directly in an application schema, if no changes are required.

Following ISO 19109, the feature types of an application or application domain are specified in an application schema. A GML application schema is specified in XML Schema and import the GML schema. It may be constructed in one of two different ways:

- by adhering to the rules for GML application schemas specified in Clause 21 for creating a GML application schema directly in XML Schema,
- by adhering to the rules specified in ISO 19109 for application schemas in UML, and conforming to both the constraints on such schemas and the rules for mapping them to GML application schemas specified in Annex E of this International Standard. The mapping from an ISO 19109 conformant Application Schema in UML to the corresponding GML application schema is based on a set of encoding rules. These encoding rules conform with the rules for GML application schemas and ISO 19118.

Both ways are valid approaches to construct GML application schemas. All application schemas are modelled in accordance with the General Feature Model specified in ISO 19109. Within the ISO 19100 series, UML is the preferred language to describe conceptual schemas.

The second approach is recommended in general to ensure proper use of the conceptual modelling framework of the ISO 19100 series of International Standards. However, the following reasons are examples where it may be justified to apply the first approach:

- Additional capabilities of the GML schema may be required in addition to the capabilities that are accessible by using the encoding rules specified in Annex E.
- Only an XML representation may be required and the application schema may be relatively simple, so the use of a conceptual schema language may be considered an unjustified overhead.
- The application may need a more optimised or compact XML encoding than the one that is the result of the encoding rules specified in Annex E.

NOTE Annex F provides rules for mapping a GML application schema to an ISO 19109 conformant Application Schema in UML.

In both cases, GML application schemas conformant with this International Standard use all of the applicable GML schema components, either directly or by specialization, and are valid according to the rules for XML Schema. How the GML application schemas were produced is not relevant for conformance to the requirements of this International Standard.

The approach taken by this International Standard is shown in Figure 36. The two main aspects are:

- Clear documentation of the conceptual model of GML: The profile of the ISO 19100 series of International Standards that is implemented by GML is documented as well as the extensions to this profile.
- Support for application schema development either in UML or XML Schema: In order to achieve this twoway mapping between UML (i.e. ISO 19109 conformant application schemas in UML) and XML Schema (i.e. GML application schemas in XML Schema) the constructs used in both representations have been limited. While this reduces the expressiveness of the schema descriptions to some extent, this also reduces their complexity and may make them easier to implement.

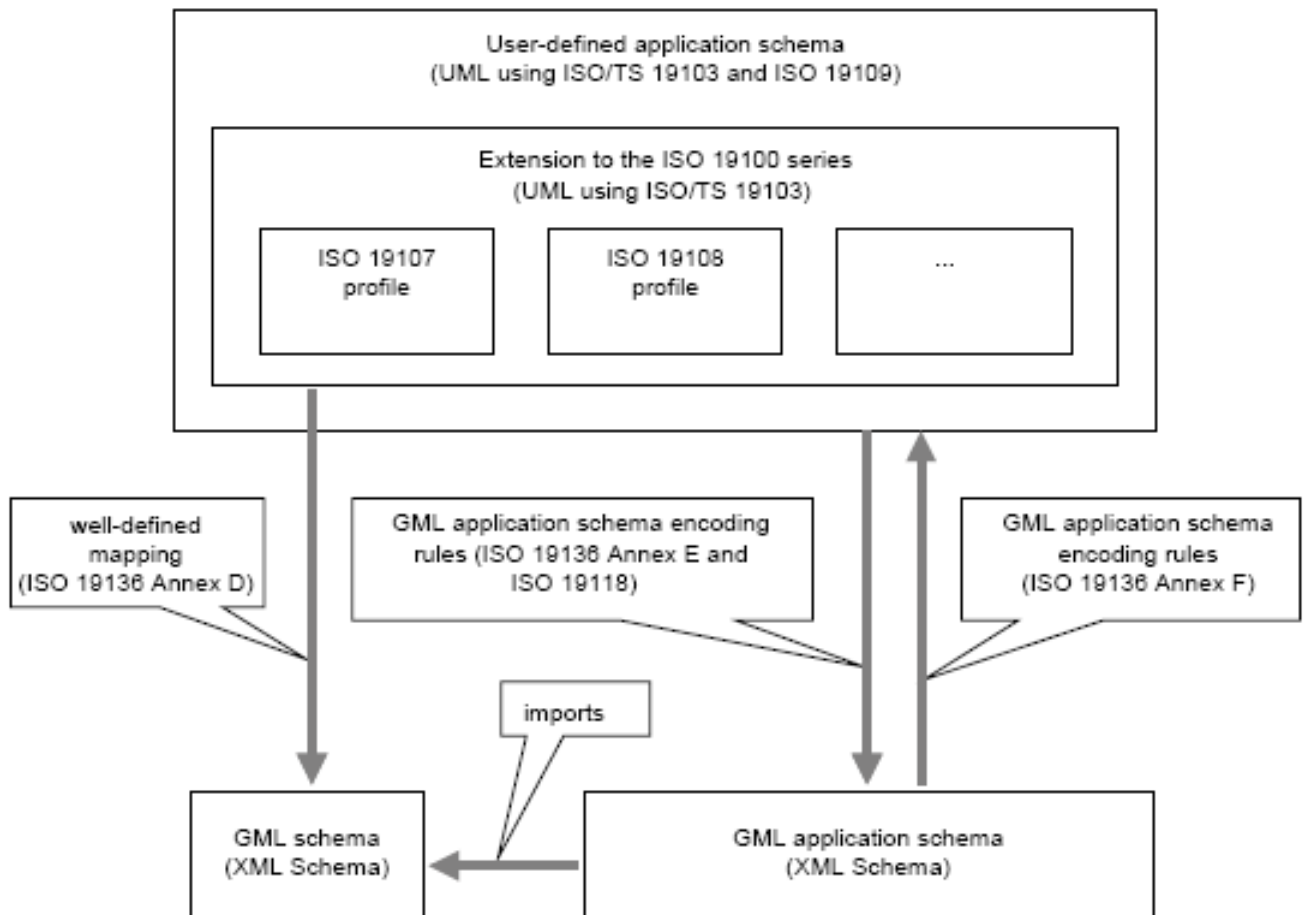

Figure 36 — Relationship between the ISO 19100 series of International Standards and ISO 19136 GML

ISO/TS 19139:2007 GEOGRAPHIC INFORMATION — METADATA — XML SCHEMA IMPLEMENTATION

This Technical Specification defines Geographic MetaData XML (gmd) encoding, an XML schema implementation derived from ISO 19115.

Since ISO 19115 does not provide any encoding, the actual implementation of geographic information metadata could vary based on the interpretation of metadata producers. In an attempt to facilitate the standardization of implementations, this comprehensive metadata implementation specification provides a definitive, rule-based encoding for applying ISO 19115. This Technical Specification provides Extensible Markup Language (XML) schemas that are meant to enhance interoperability by providing a common specification for describing, validating and exchanging metadata about geographic datasets, dataset series, individual geographic features, feature attributes, feature types, feature properties, etc.

ISO 19118 describes the requirements for creating encoding rules based on UML schemas and the XML-based encoding rules as well as providing an introduction to XML. This Technical Specification utilizes the encoding rules defined in ISO 19118 and provides the specific details of their application with regard to deriving XML schema for the UML models in ISO 19115.

STANDARDS FOR SPECIFIC THEMATIC AREAS

The early work in ISO/TC 211 was focused on developing standards to support a broad range of capabilities required by all applications of geographic information. As that work has been completed there has been movement toward developing standards to support specific thematic application areas. The first of these to produce published standards is the area of geographic imagery.

ISO/TS 19101-2 extends the first part of ISO 19101 to specify a reference model for standardization in the field of geographic imagery processing. ISO 19115-2 extends ISO 19115, adding 138 additional metadata elements for describing imagery datasets.

Additional thematic areas for which standards are in development or under consideration include land use classification, cadastre, and addressing systems.

ISO/TS 19101-2:2008 GEOGRAPHIC INFORMATION — REFERENCE MODEL —
PART 2: IMAGERY

This Technical Specification defines a reference model for standardization in the field of geographic imagery processing. This reference model identifies the scope of the standardization activity being undertaken and the context in which it takes place. The reference model includes gridded data with an emphasis on imagery. Although structured in the context of information technology and information technology standards, this Technical Specification is independent of any application development method or technology implementation approach.

The central concept of the enterprise viewpoint is how the geographic imagery community interacts to enable imagery collected from different sources to become an integrated digital representation of the Earth widely accessible for humanity's critical decisions. The enterprise viewpoint provides the metric traceability between this objective and the system design for distributed geographic imagery processing systems.

The fundamental goal of the geographic imagery community is to advance and protect interests of humanity by development of imaging capabilities, and by sustaining and enhancing the geographic imagery industry. Doing so will also foster economic growth, contribute to environmental stewardship, and enable scientific and technological excellence.

The Information Viewpoint identifies various types of geographic information characterizing Geographic Imagery Scenes. The Information Viewpoint is structured following an integrated approach to geographic imagery showing relationships of raw sensed data to higher semantic content information and knowledge. The resulting structure of the Information Viewpoint is reflected in the UML packages identified in Figure 37. The contents of these packages are addressed in 7.2 – 7.5 of this Information Viewpoint.

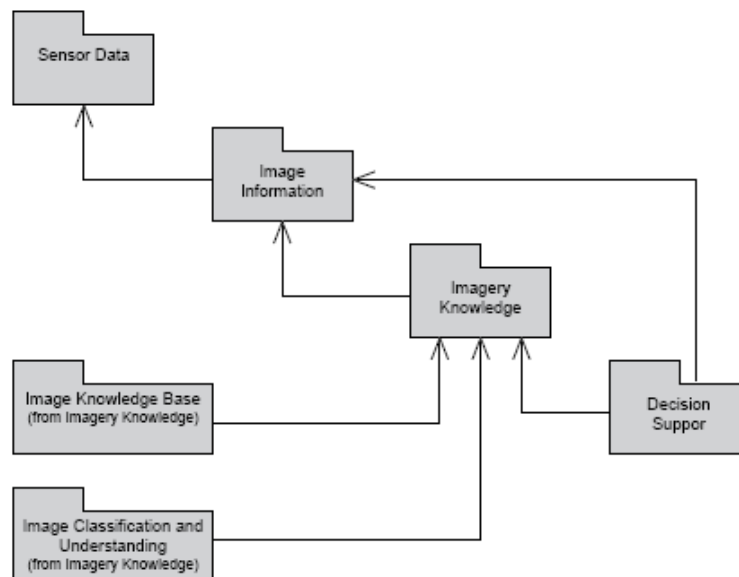

Figure 37 — Information Viewpoint packages

The computational viewpoint provides a transition from the Information Viewpoint to the distributed deployment represented in the Engineering Viewpoint. The Computational Viewpoint provides a perspective for describing distribution through functional decomposition of the system into objects that interact at interfaces.

Geographic imagery services are specified as extensions of the broader geographic services defined in ISO 19119. ISO 19119 defines a geographic services taxonomy based on the semantic characteristics of services and provides examples. That taxonomy consists of the titles of the categories and the definitions for the categories.

ISO 19119 and OGC Image Exploitation Services provide more detail concerning the geographic imagery services for:

- human interaction,
- model/information management,
- workflow/task management,
- processing for spatial, thematic, temporal, and metadata,
- communication.

The Engineering viewpoint on an ODP system and its environment focuses on the mechanisms and functions required to support distributed interaction between objects in the system (Figure 38).

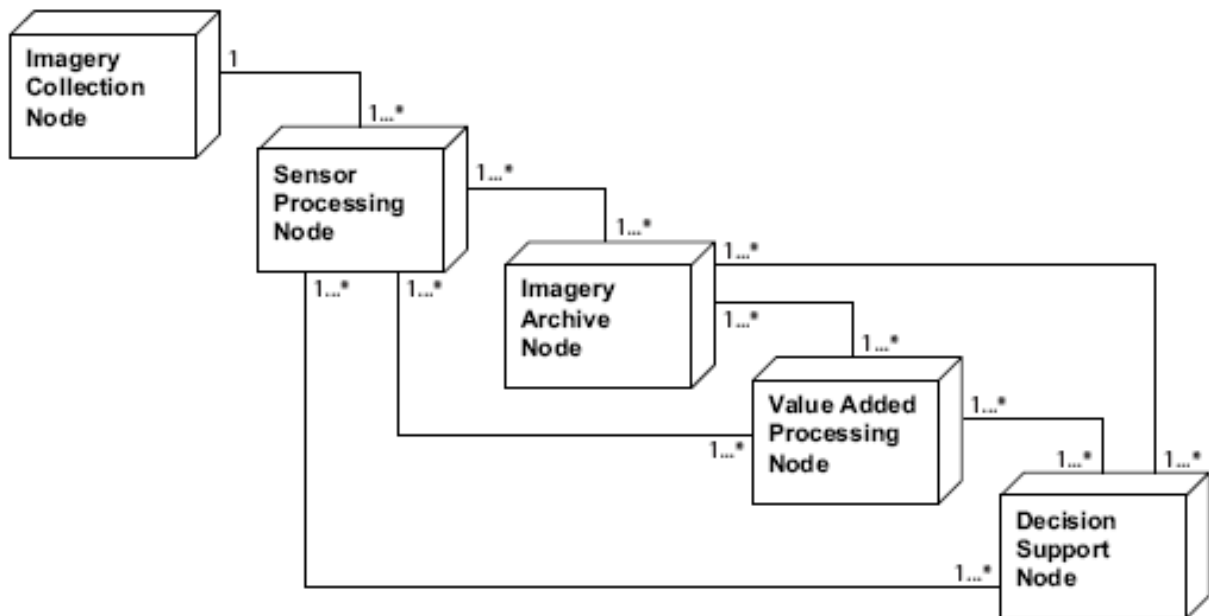

Figure 38 — Geographic imagery system deployment diagram

ISO/TS 19115-2:2008 GEOGRAPHIC INFORMATION — METADATA —
PART 2: EXTENSIONS FOR IMAGERY AND GRIDDED DATA

ISO 19115 identifies the metadata required to describe digital geographic data. This part of ISO 19115 extends the metadata identified in ISO 19115 and identifies the metadata required to describe digital geospatial imagery and gridded data. ISO 19115 identifies some of the metadata for imagery and gridded data and this part of ISO 19115 builds upon that foundation. It adds 138 metadata elements to those provided by the first part. It provides information about the properties of the measuring equipment used to acquire the data, the geometry of the measuring process employed by the equipment, and the production process used to digitize the raw data. This extension deals with metadata needed to describe the derivation of geographic information from raw data, including the properties of the measuring system, and the numerical methods and computational procedures used in the derivation. The metadata required to address coverage data in general is addressed sufficiently in the general part of ISO 19115.

The extended metadata are provided for geographic image and gridded datasets which include the geospatial imagery and gridded data and may optionally be provided for aggregations of datasets.

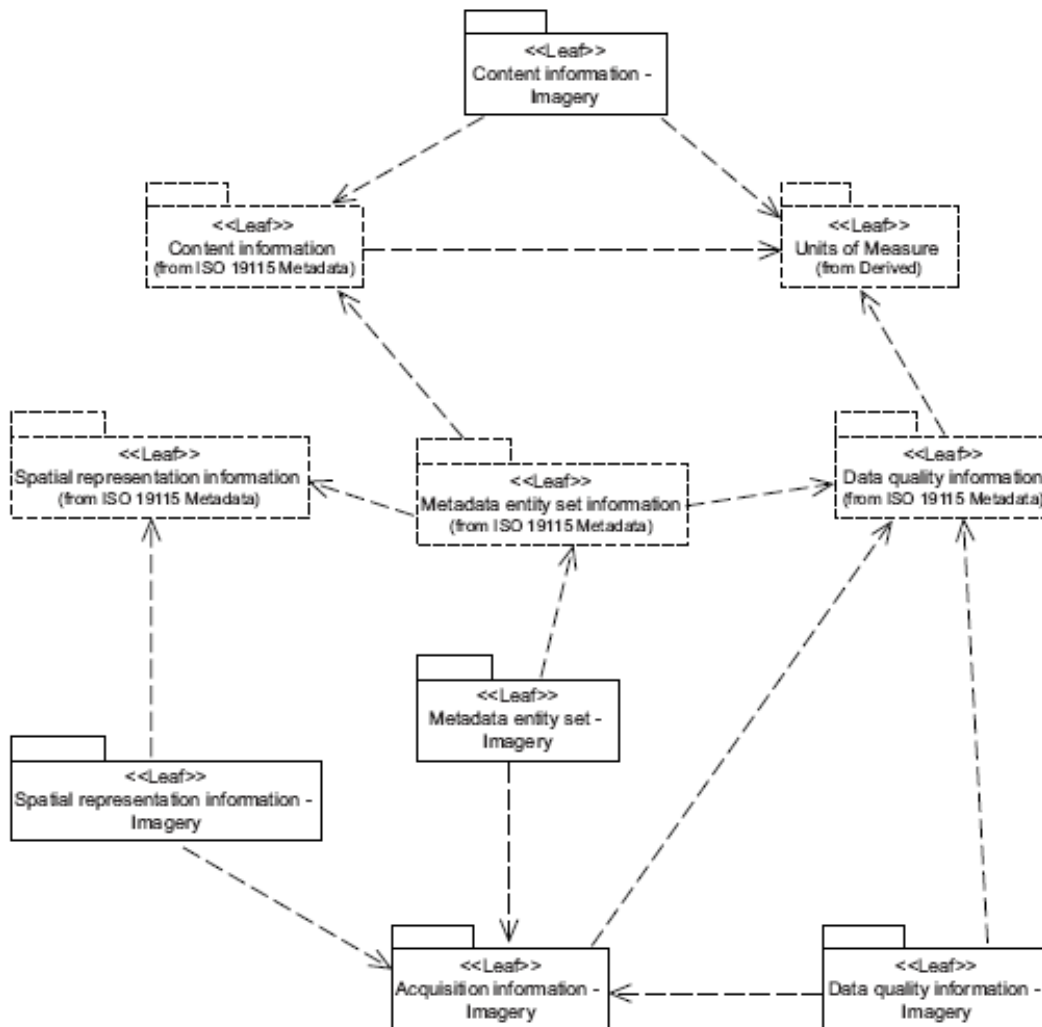

Figure 39 — Imagery metadata packages

Figure 39 illustrates the relationships among the packages described in this part of ISO 19115 and the relevant packages specified in ISO 19115. The ISO 19115 UML model diagrams and data dictionary for each package are fully specified in ISO 19115. The additional metadata for geospatial

imagery and gridded data is fully specified in the UML model diagrams and data dictionary for each additional package, which can be found in Annex A and Annex B, respectively.

ISO/TC 211 AND THE OPEN GEOSPATIAL CONSORTIUM

ISO/TC 211 and the Open Geospatial Consortium (OGC) established a cooperative agreement in 1998. Under this agreement, The OGC has adopted several ISO/TC 211 standards as abstract specifications on which to base their own work on implementation specifications:

ISO/TC 211 Standard

OGC Abstract Specification

ISO 19107 Geographic information – Spatial schema	Topic 1 – Feature Geometry
ISO 19111 Geographic information – Spatial referencing by coordinates	Topic 2 – Spatial Referencing by Coordinates
ISO 19123 Geographic information – Coverage geometry and functions	Topic 6 – Coverage Geometry and Functions
ISO 19115 Geographic information – Metadata	Topic 11 – Metadata
ISO 19119 Geographic information – Services	Topic 12 – The Open GIS Service Architecture

In addition, a number of standards developed initially by the OGC have been brought to ISO/TC 211 and, after further development, published as ISO International Standards. These include:

- ISO 19123 Geographic information — Coverage geometry and functions
- ISO 19125-1 Geographic information — Simple feature access — Part 1: Common architecture
- ISO 19125-2 Geographic information — Simple feature access — Part 2: SQL option
- ISO 19128 Geographic information — Web map server interface

Several additional OGC standards are in work in ISO/TC 211. These include:

- ISO 19142 Geographic information — Web Feature Service
- ISO 19143 Geographic information — Filter encoding
- ISO 19149 Geographic information — Rights expression language for geographic information — GeoREL
- ISO 19153 Geospatial Digital Rights Management Reference Model (GeoDRM RM)
- ISO 19156 Geographic information — Observations and measurements